



VIDAWO

Windows | Doors | Shutters
MANUFACTURER

1/2023

Passiv 92mm Classik „R”

PSV-92-CLS-R



Passiv 92mm Classik „S”

Passiv 92mm Classik „R”

PSV-92-CLS-R-001

out

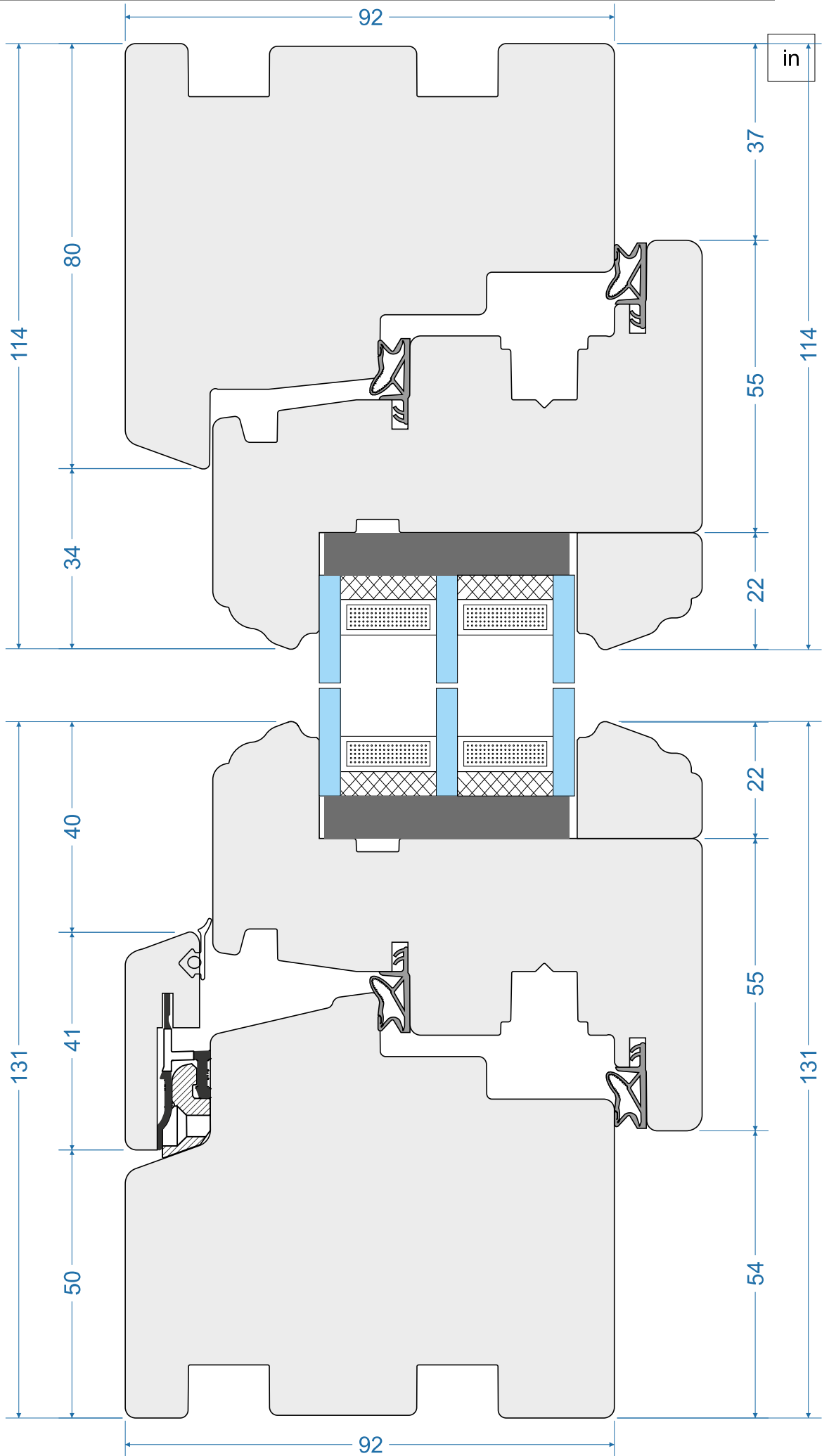



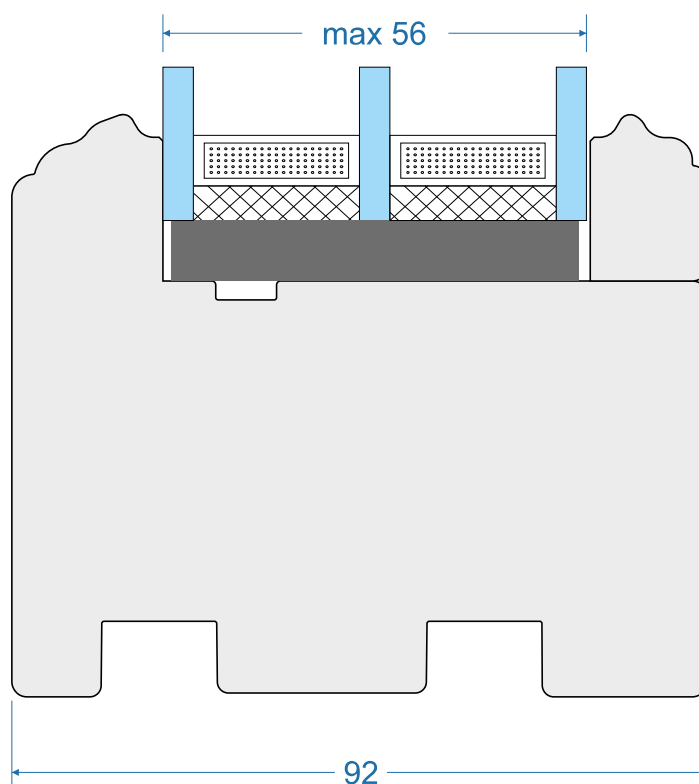
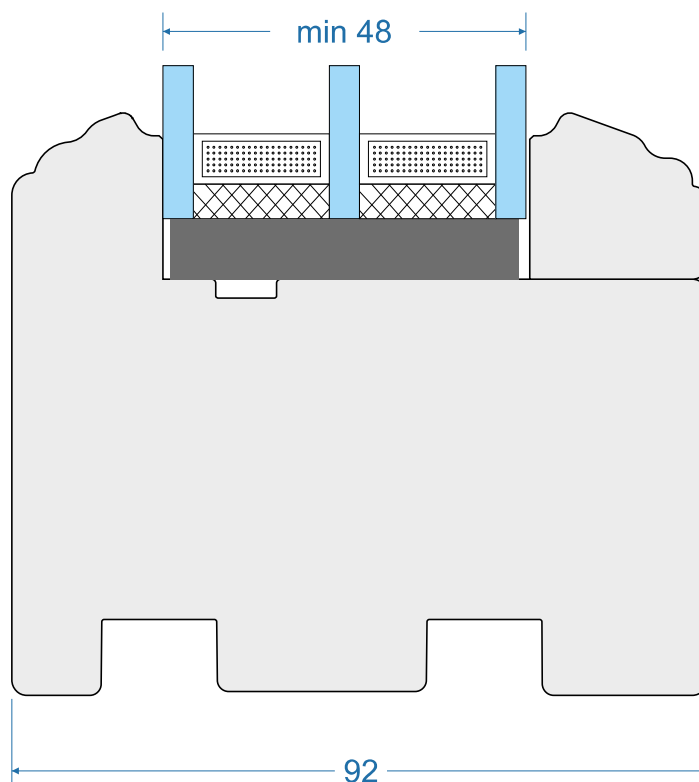

PSV-92-CLS-R-002

out

in



-  Minimalna / maksymalna grubość pakietu szybowego
-  Minimum / maximum glass thickness
-  Épaisseur minimale / maximale du verre
-  Spessore minimo/massimo del vetro
-  Minimale / maximale Stärke des verglasungs paketes

out

in

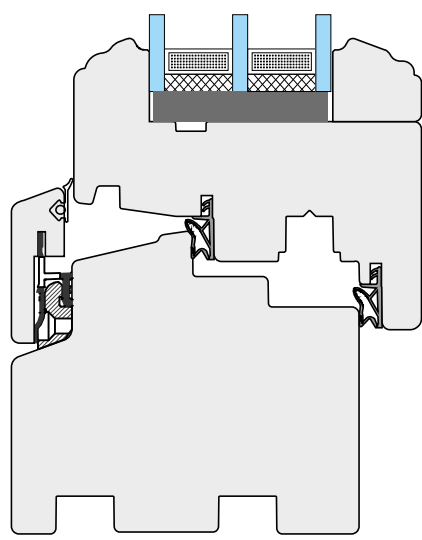



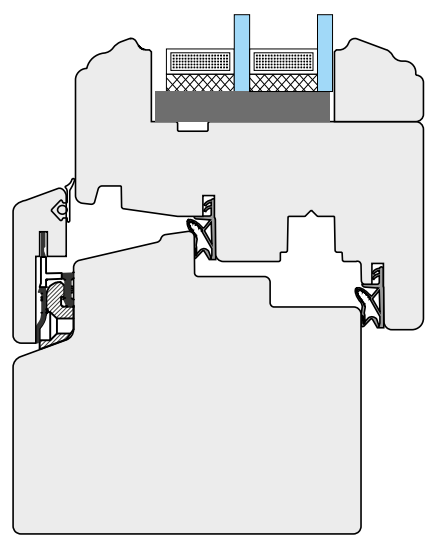

92 DN

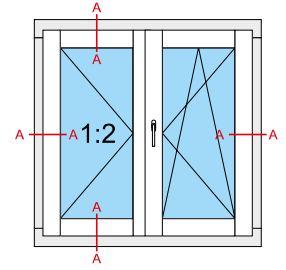

R3



-  Stabdardowe frezowanie ramy
-  Standard frame finish
-  Finition de cadre standard
-  Finitura telaio standard
-  Standard-Rahmenausführung

out

in

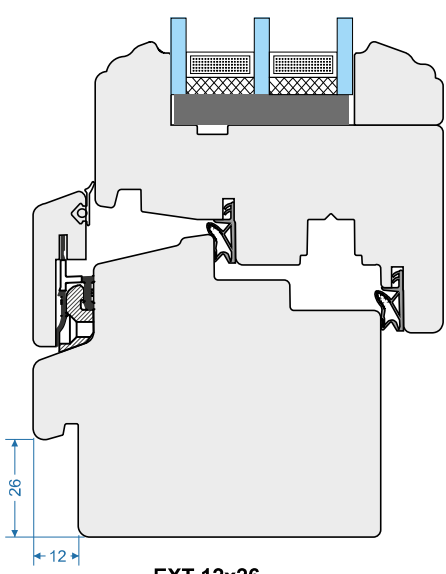



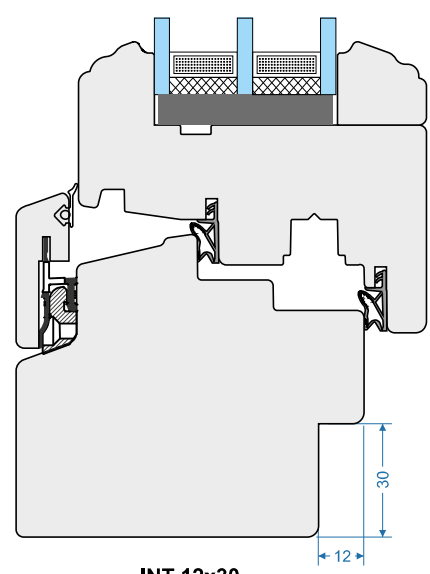

EXT 12x26

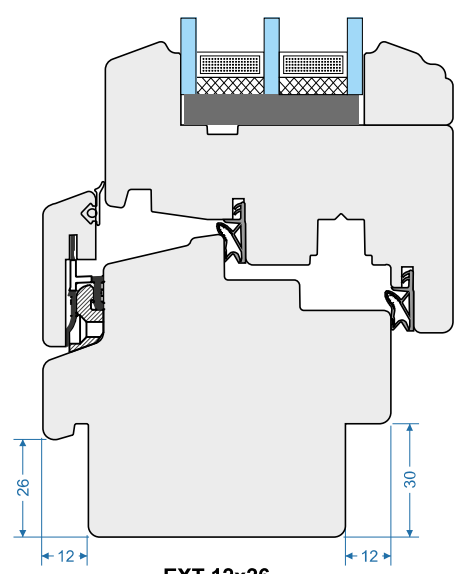

INT 12x30



EXT 12x26
INT 12x30



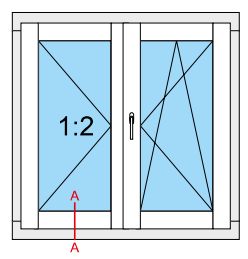

-  Frezy pod parapety
-  Groove for the window sill
-  Rainure pour le rebord de la fenêtre
-  Scanalatura per il davanzale della finestra
-  Nut für die Fensterbank

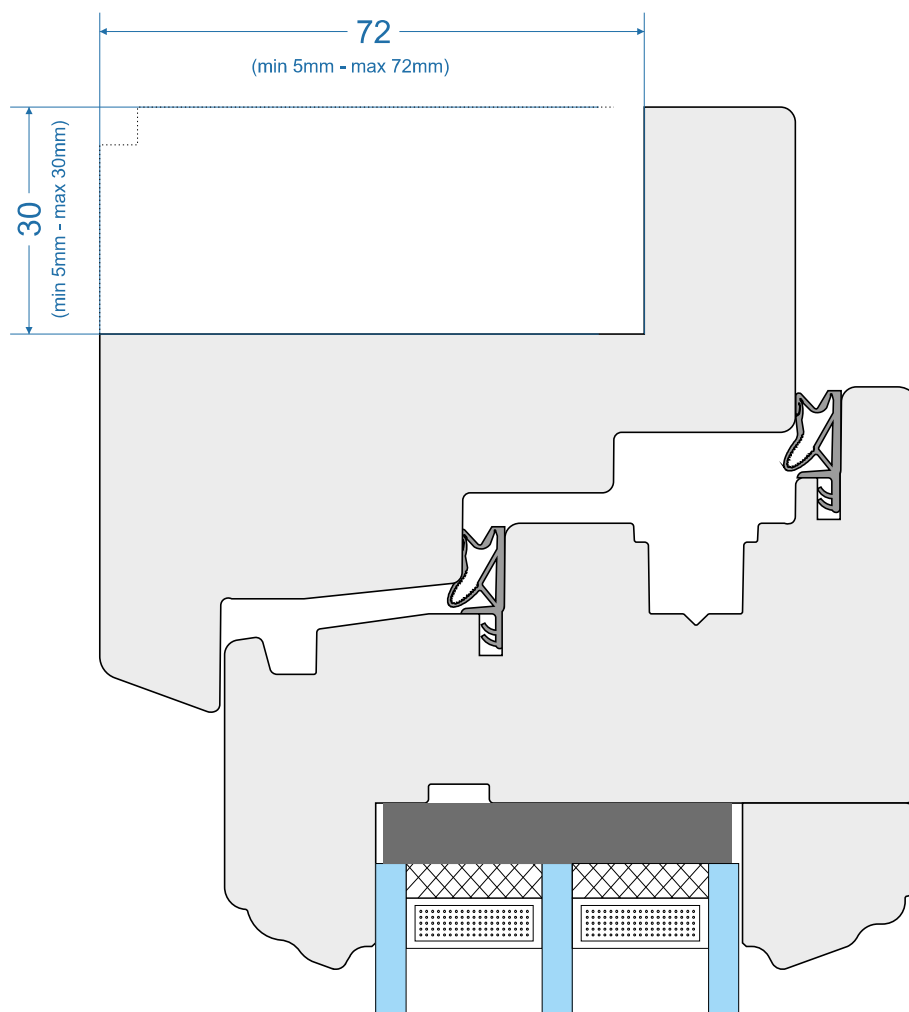

out

in



-  Frez renowacyjny od zewnątrz
-  Renovation groove from the outside
-  Rainure de rénovation à l'extérieur
-  Scanalatura di ristrutturazione all'esterno
-  Renovierungsnut außen

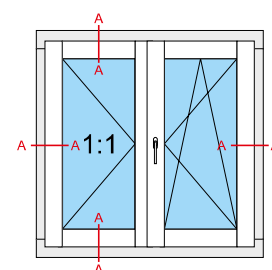



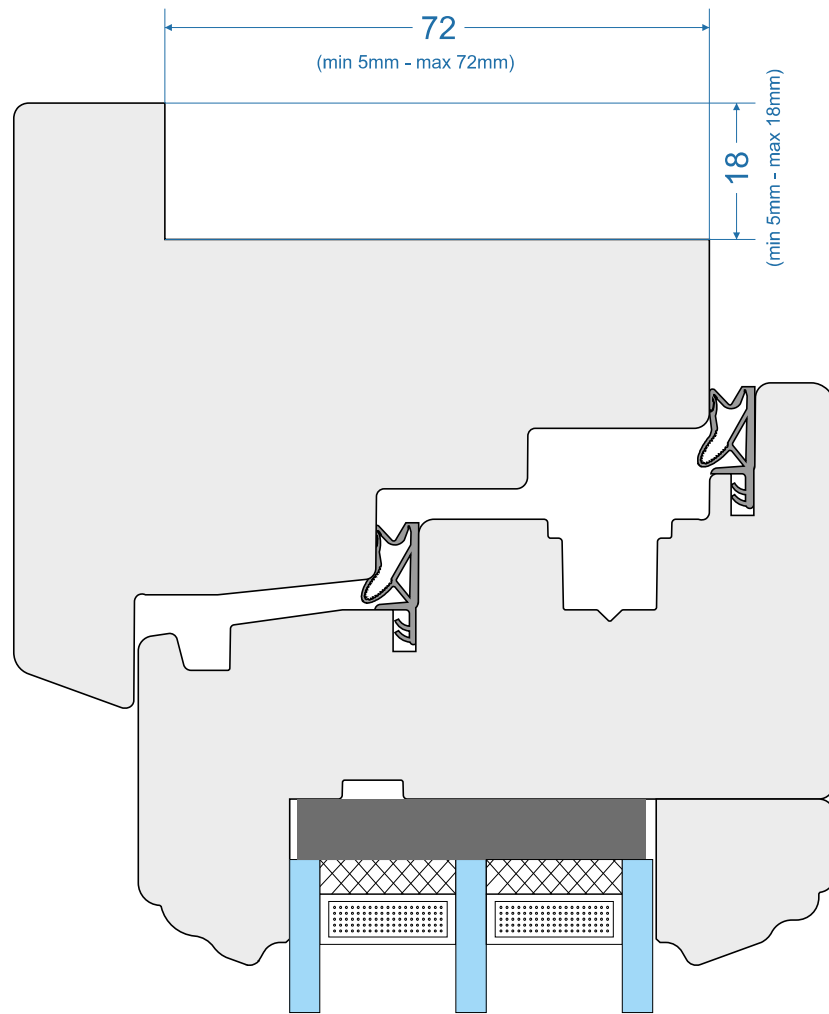

PSV-92-CLS-R-005

out

in





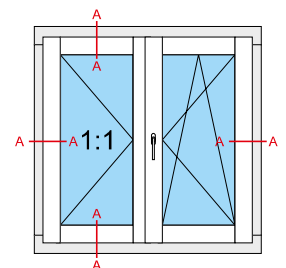

-  Frez renowacyjny od wewnątrz
-  Renovation groove from the inside
-  Rainure de rénovation à l'intérieur
-  Scanalatura di ristrutturazione all'interno
-  Renovierungsnut auf der Innenseite

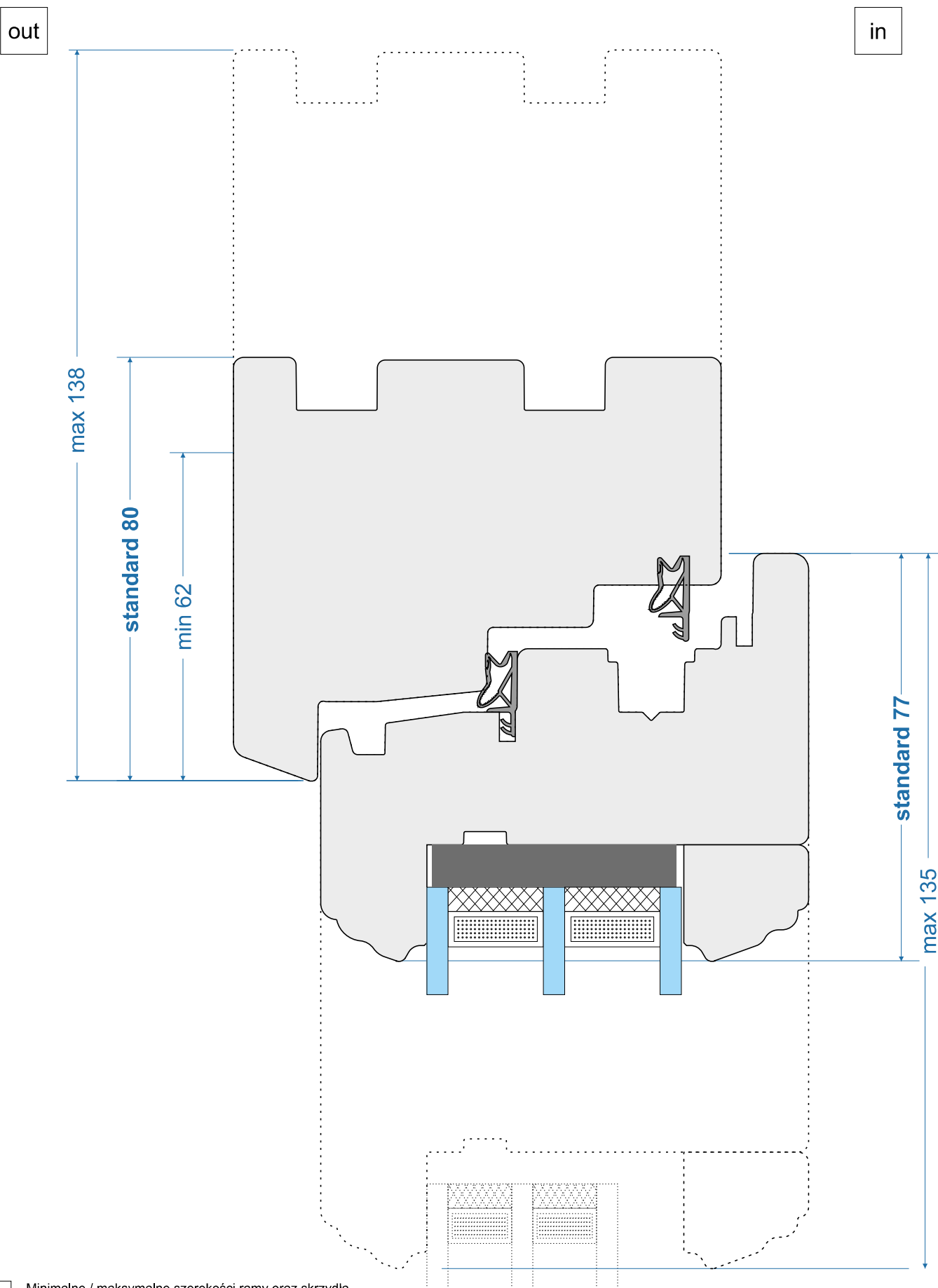

PSV-92-CLS-R-006



-  Minimalne / maksymalne szerokości ramy oraz skrzydła
-  Minimum / maximum dimensions of the frame and sash
-  Dimensions minimales / maximales du cadre et du châssis
-  Dimensioni minime/massime del telaio e dell'anta
-  Minimale / maximale breite des rahmen und des flügels

PSV-92-CLS-R-007

out

in

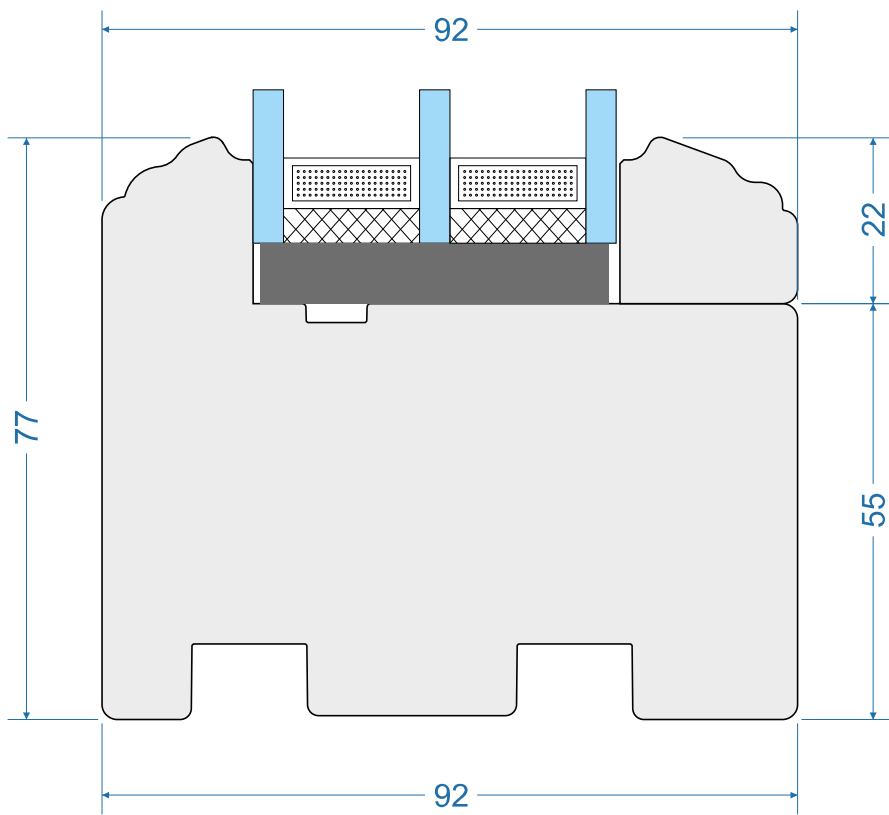

-  Fix w ramie
-  Fixed window
-  Chassis fixe
-  Finestra fissa
-  Fenster fest im rahmen

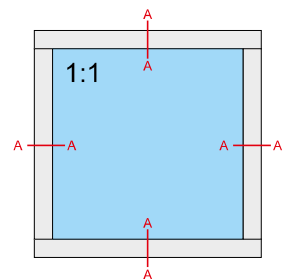

PSV-92-CLS-R-008

out

in

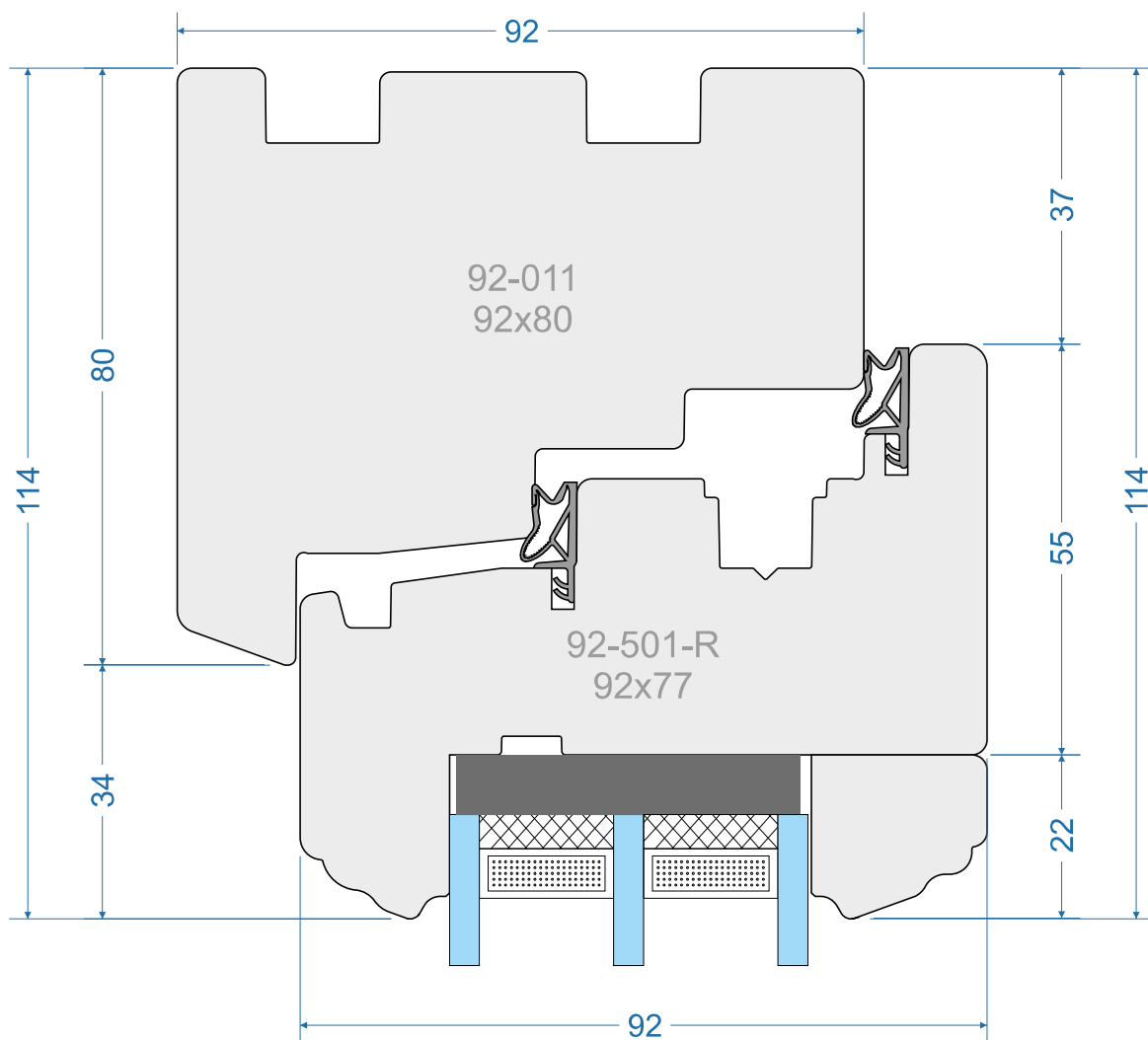

-  Rama + skrzydło
-  Frame + sash
-  Cadre + ouvrant
-  Telaio + anta
-  Rahmen + Flügel

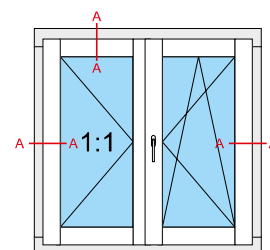

PSV-92-CLS-R-009

out

in

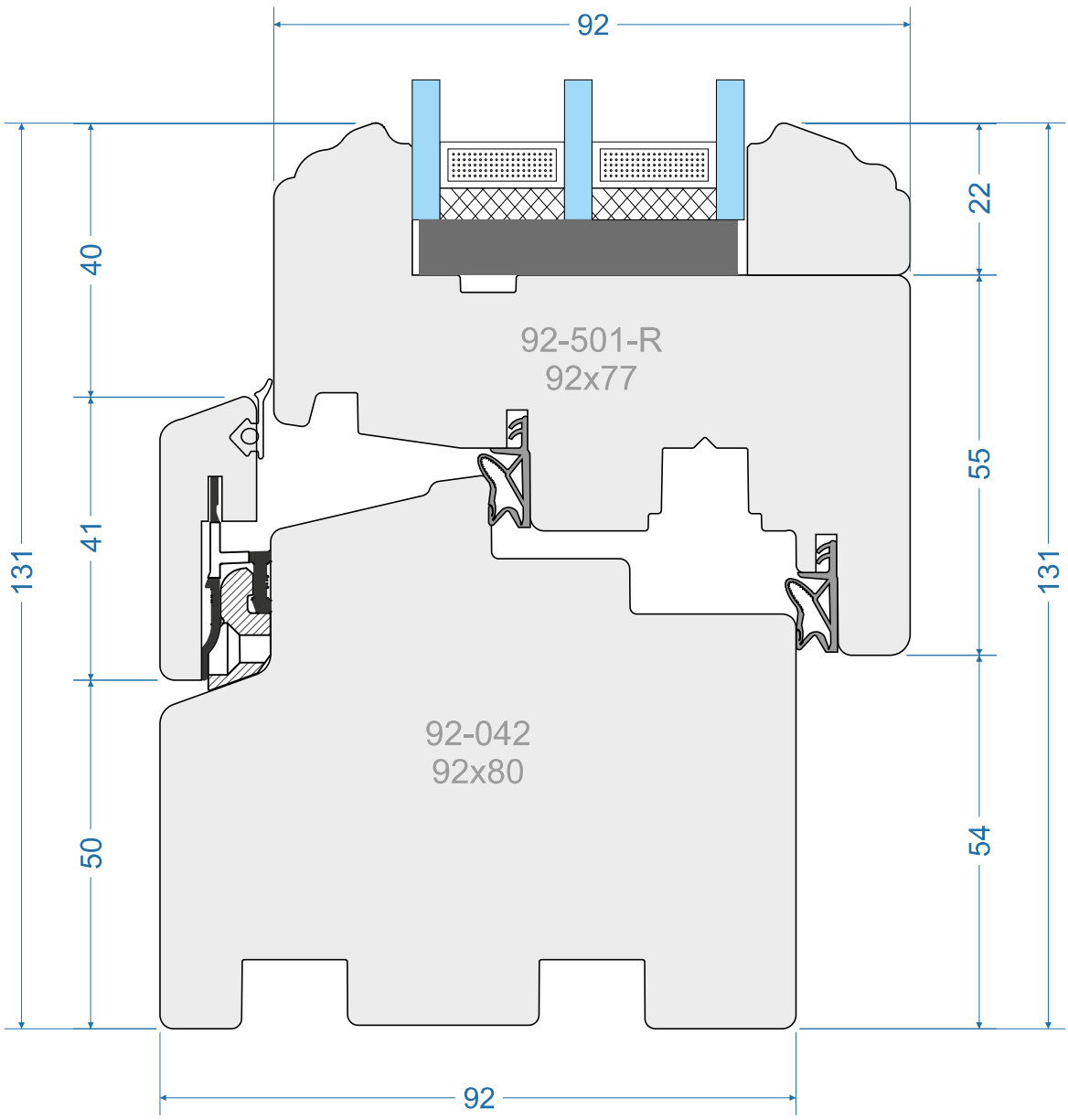

-  Rama + skrzydło
-  Frame + sash
-  Cadre + ouvrant
-  Telaio + anta
-  Rahmen + Flügel

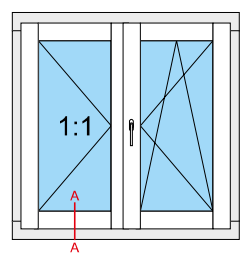

PSV-92-CLS-R-0010

out

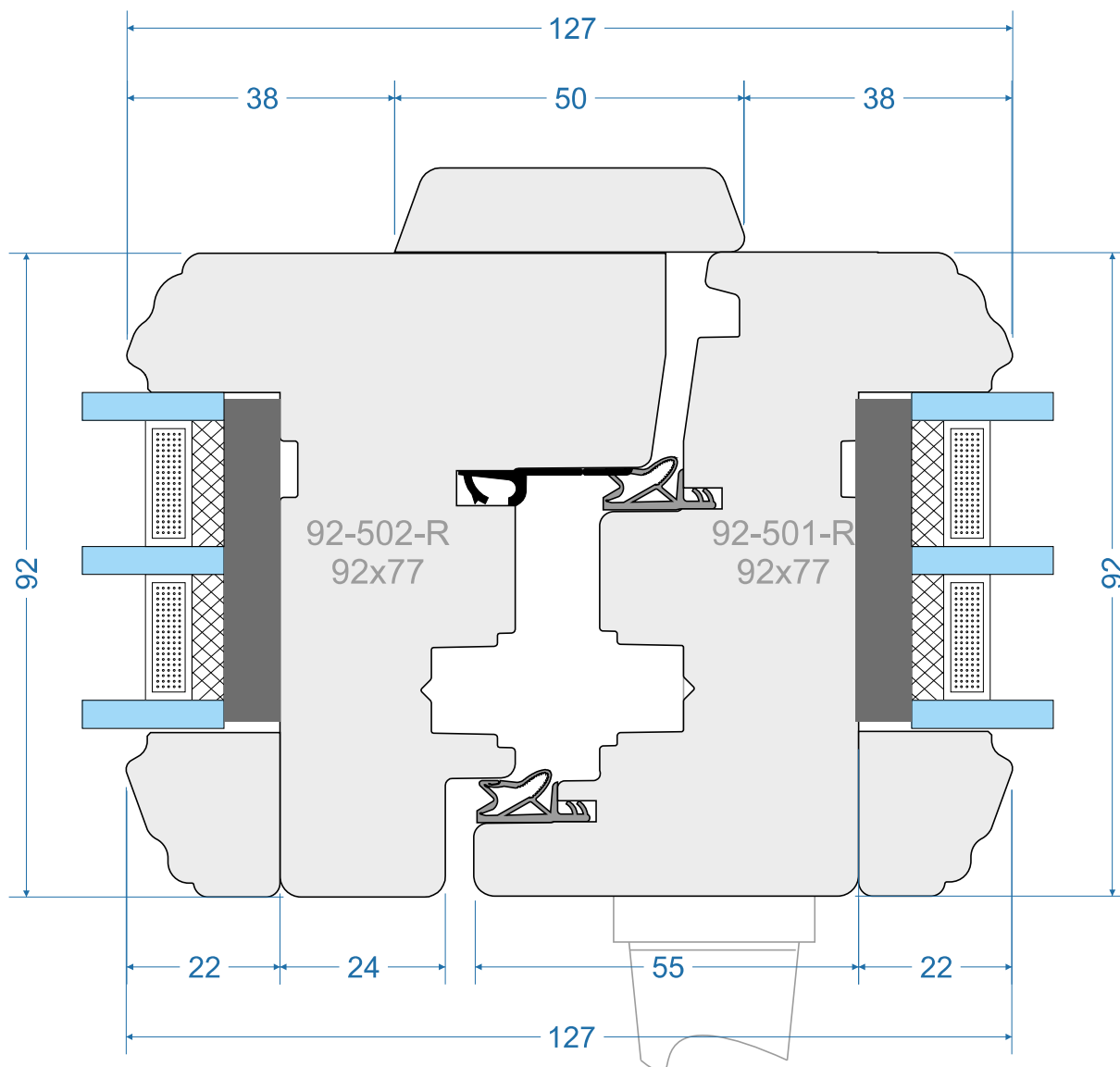

in

-  Stupek ruchomy
-  Moveable post
-  Meneau mobile
-  Montante mobile
-  Stulp

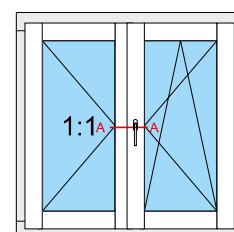



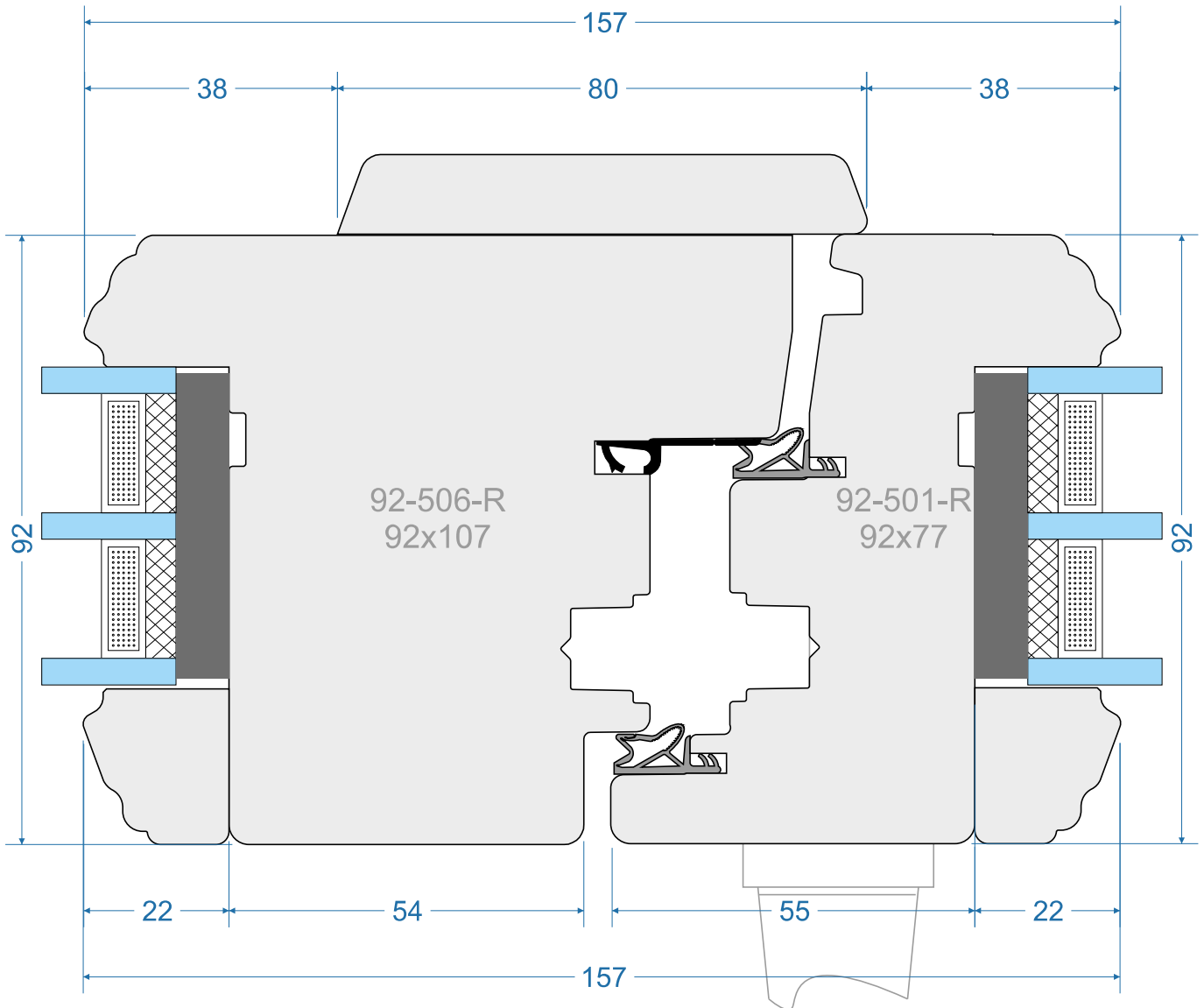

PSV-92-CLS-R-0011

out



in



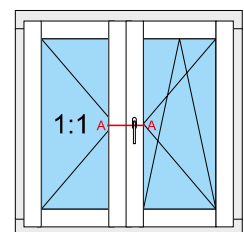

-  Stupek ruchomy - równe elementy
-  Movable post - equal elements
-  Meneau mobile - éléments égaux
-  Montante mobile - elementi simmetrici
-  Stulp - gleiche Elemente

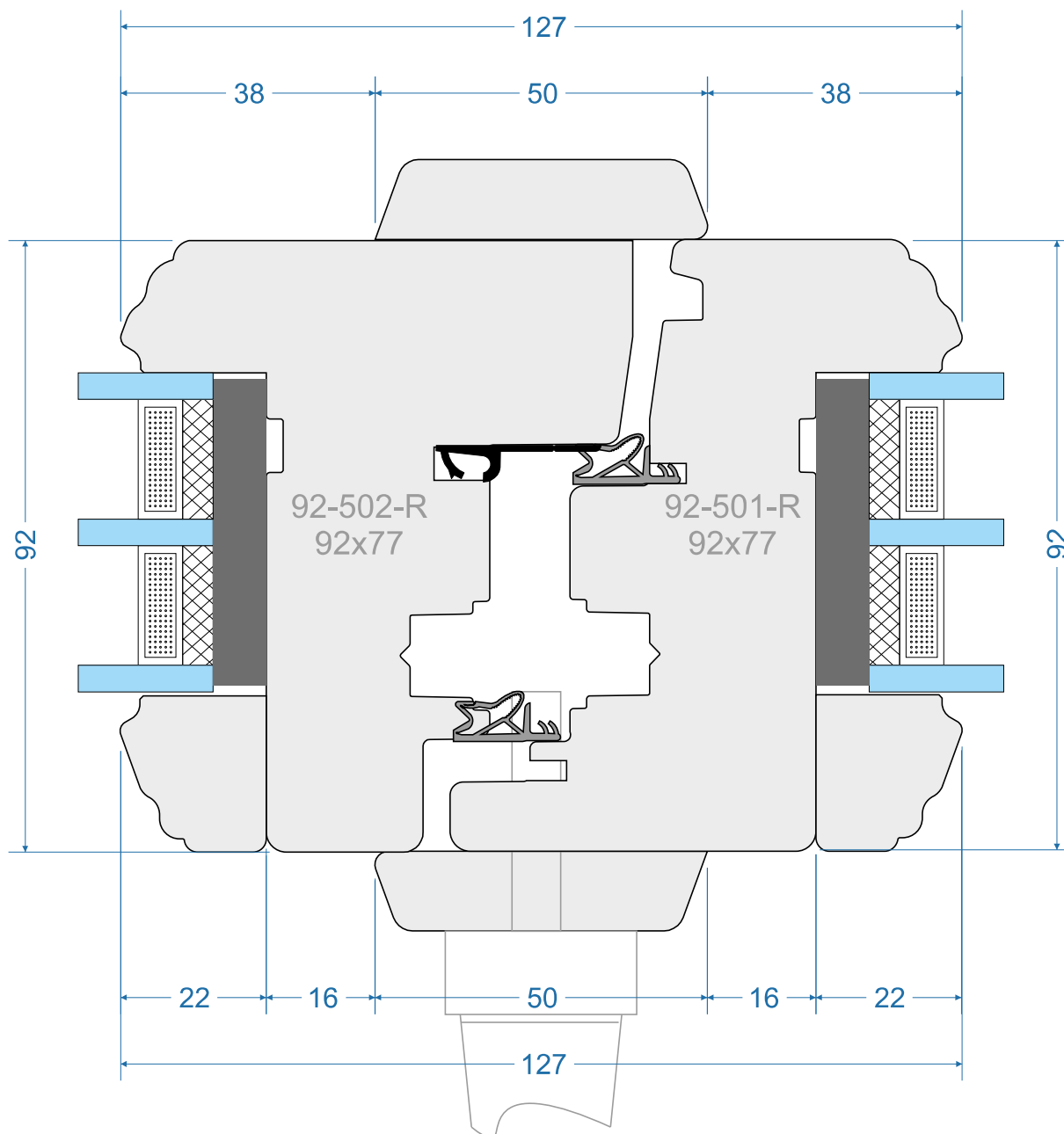

out



in

-  Stupek ruchomy - klamka centralna
-  Moveable post - central handle
-  Meneau mobile - poignée centrale
-  Montante mobile - maniglia centrale (entrata zero)
-  Stulp - zentraler Griff

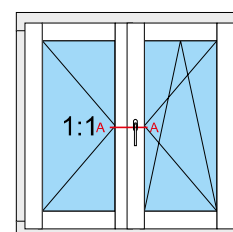



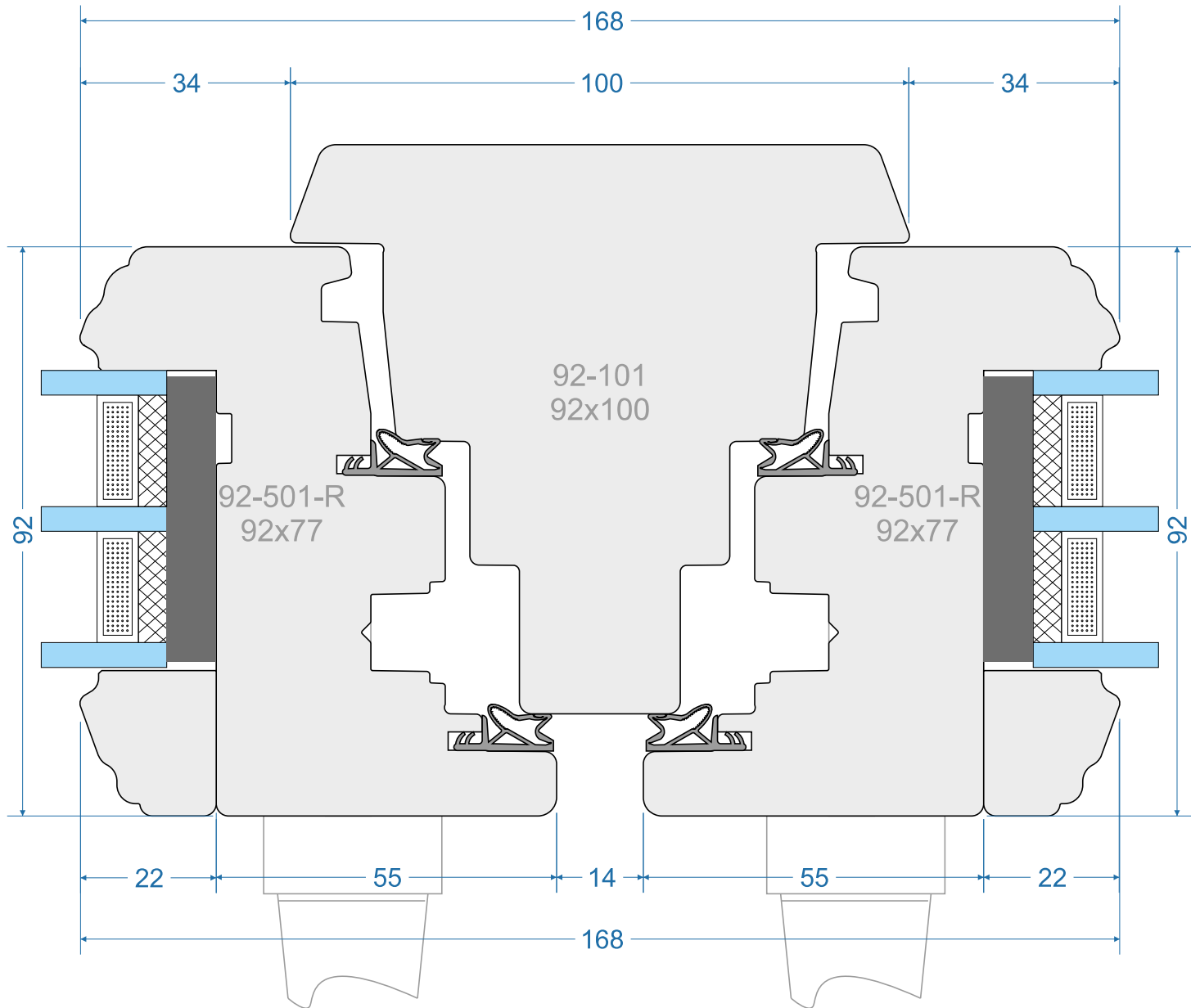

PSV-92-CLS-R-0013

out



in



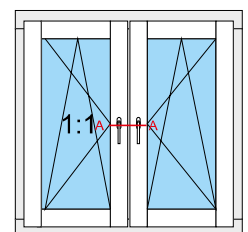

-  Slupek staly 100mm
-  Fixed post 100mm
-  Meneau fixe 100mm
-  Montante verticale fisso 100mm
-  Festen pfosten 100mm

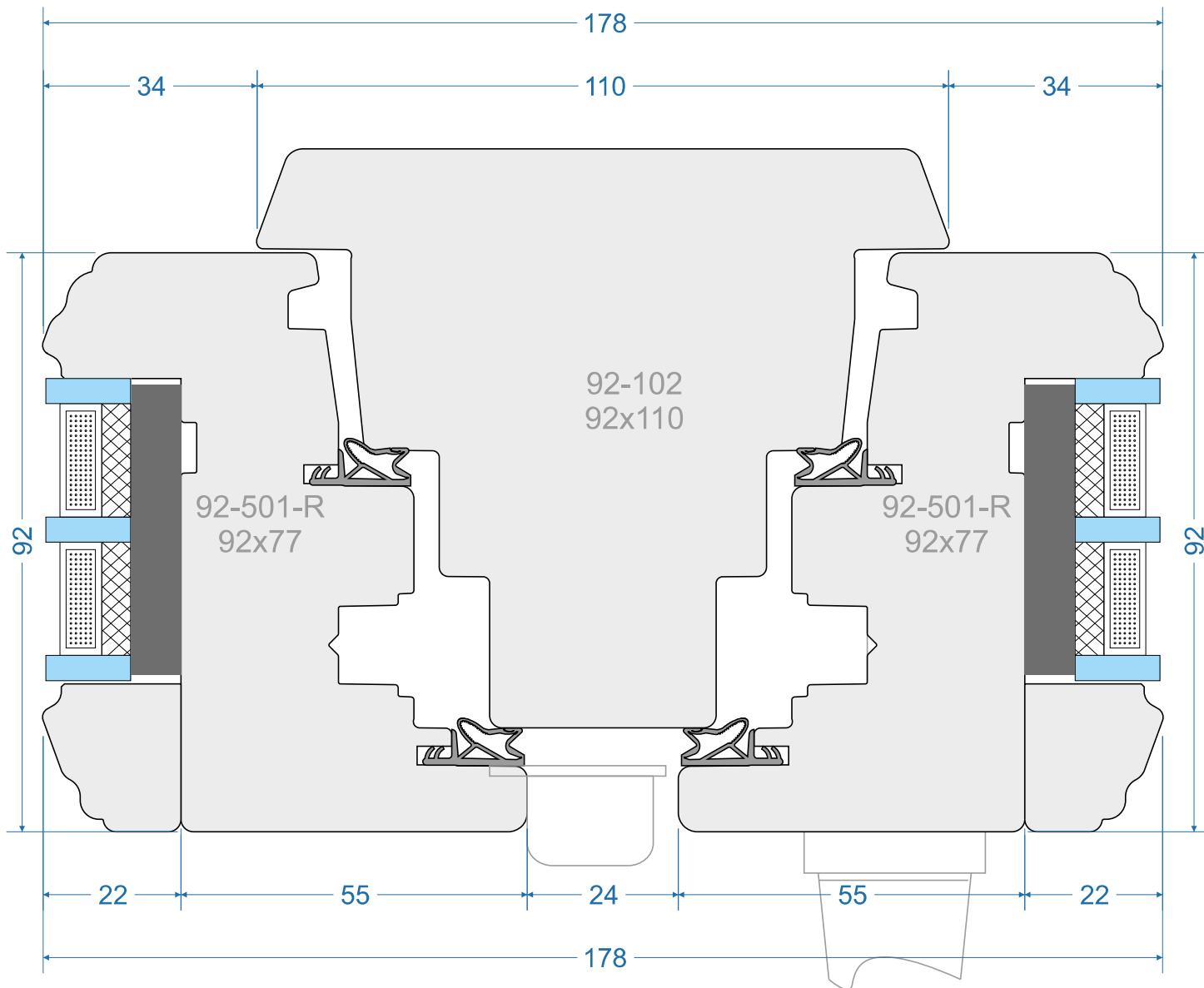

out







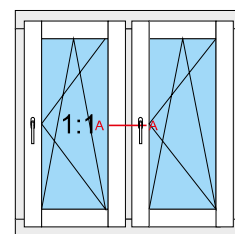

in

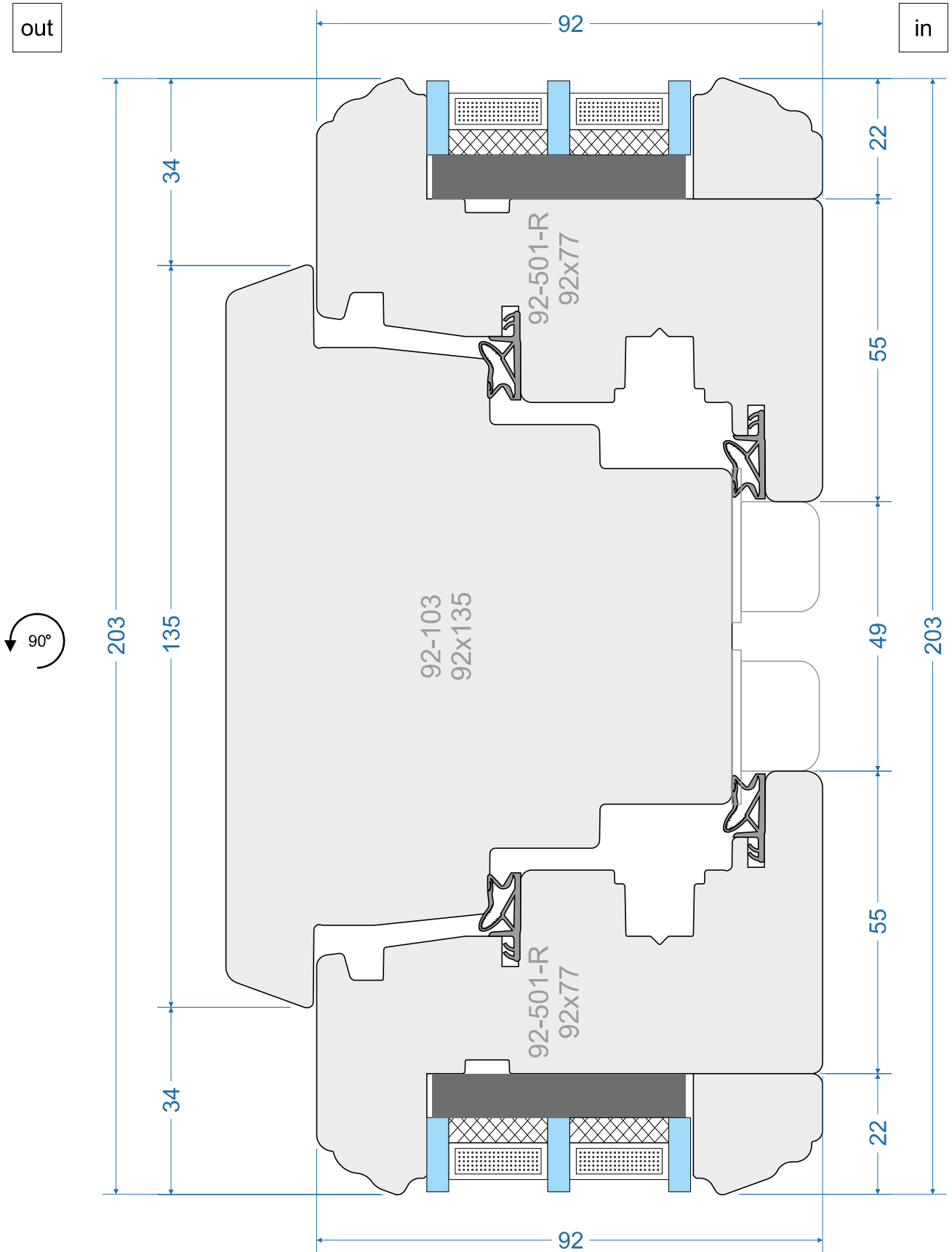
-  Słupek stalowy 110mm
-  Fixed post 110mm
-  Meneau fixe 110mm
-  Montante verticale fisso 110mm
-  Festen pfosten 110mm



PSV-92-CLS-R-0015



-  Slupek staly 135mm
-  Fixed post 135mm
-  Meneau fixe 135mm
-  Montante orizzontale fisso 135mm
-  Festen pfosten 135mm

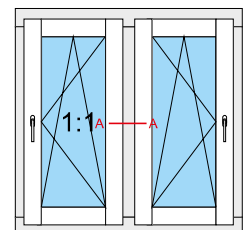



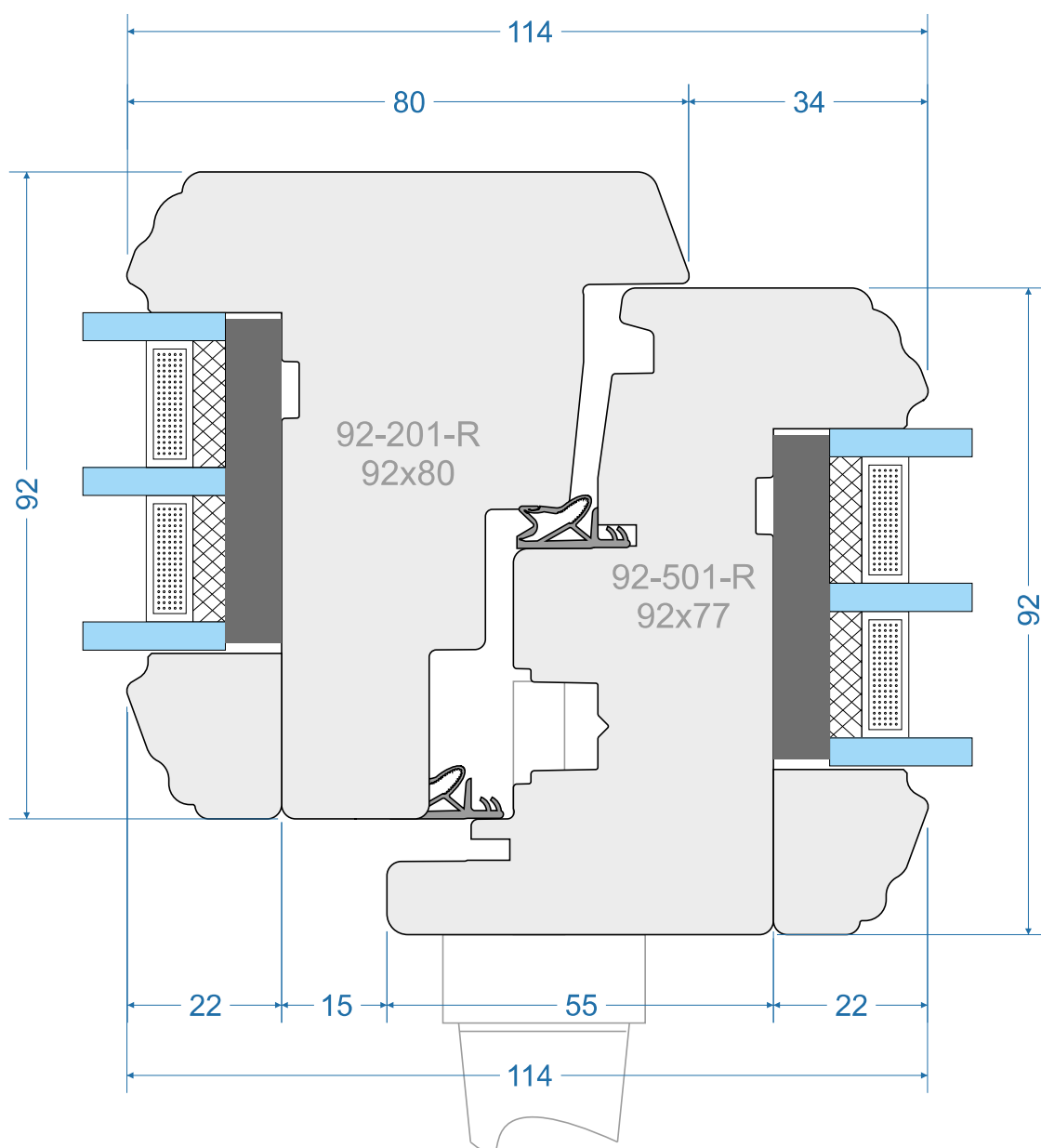

PSV-92-CLS-R-0016

out



in

-  Słupek - skrzydło + fix
-  Post - sash + fix
-  Meneau - ouvrant + fixe
-  Accoppiamento telaio fisso - anta mobile
-  Pfosten - Flügel + Fix

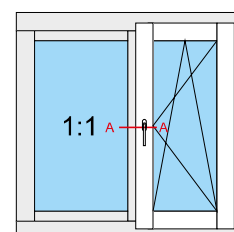



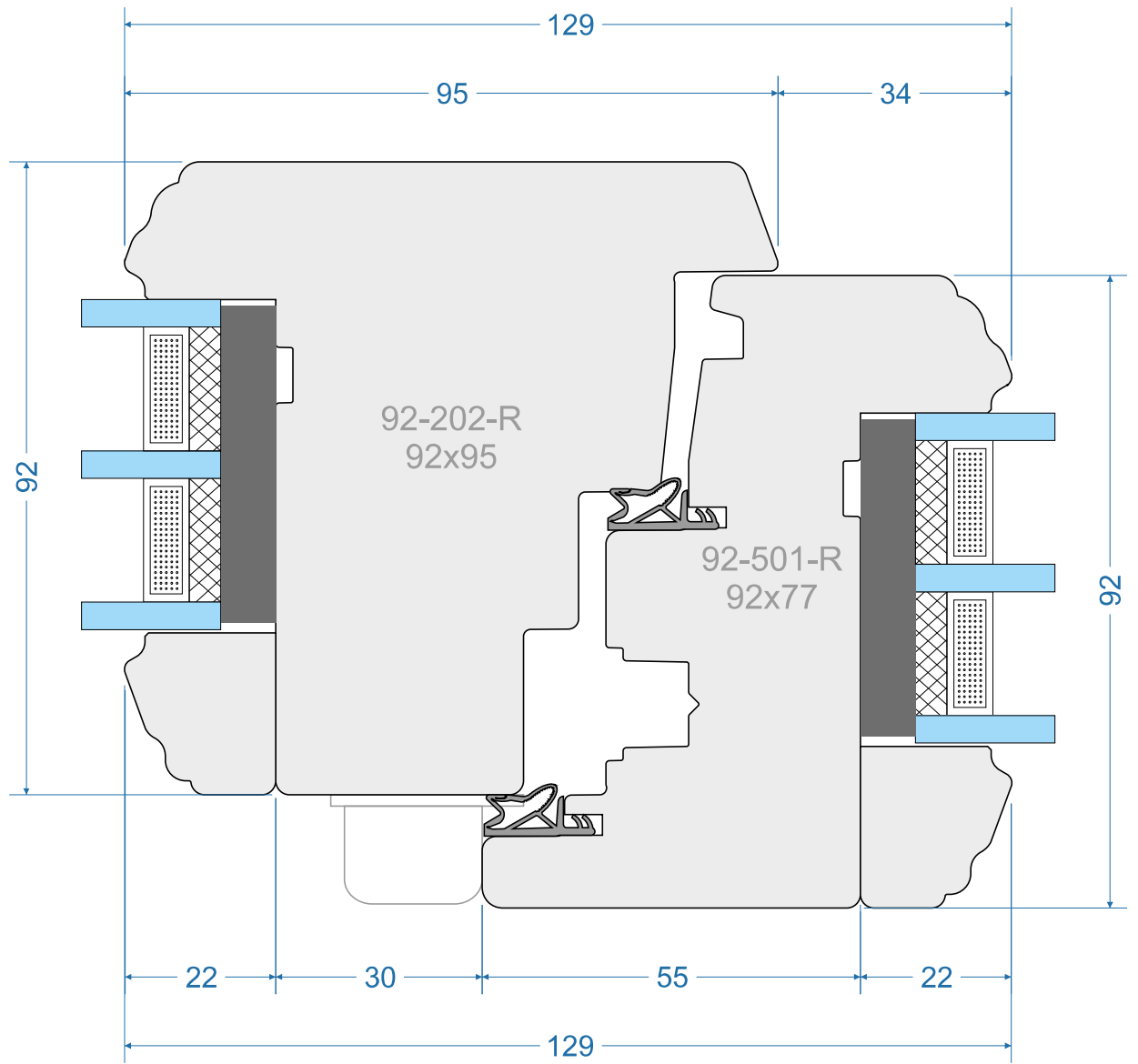

PSV-92-CLS-R-0017

out



in

-  Słupek - skrzydło + fix
-  Post - sash + fix
-  Meneau - ouvrant+ fixe
-  Accoppiamento telaio fisso - anta mobile
-  Pfosten - Flügel + Fix

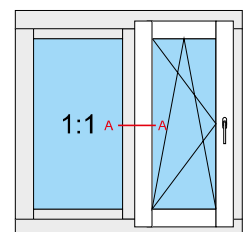

out

in

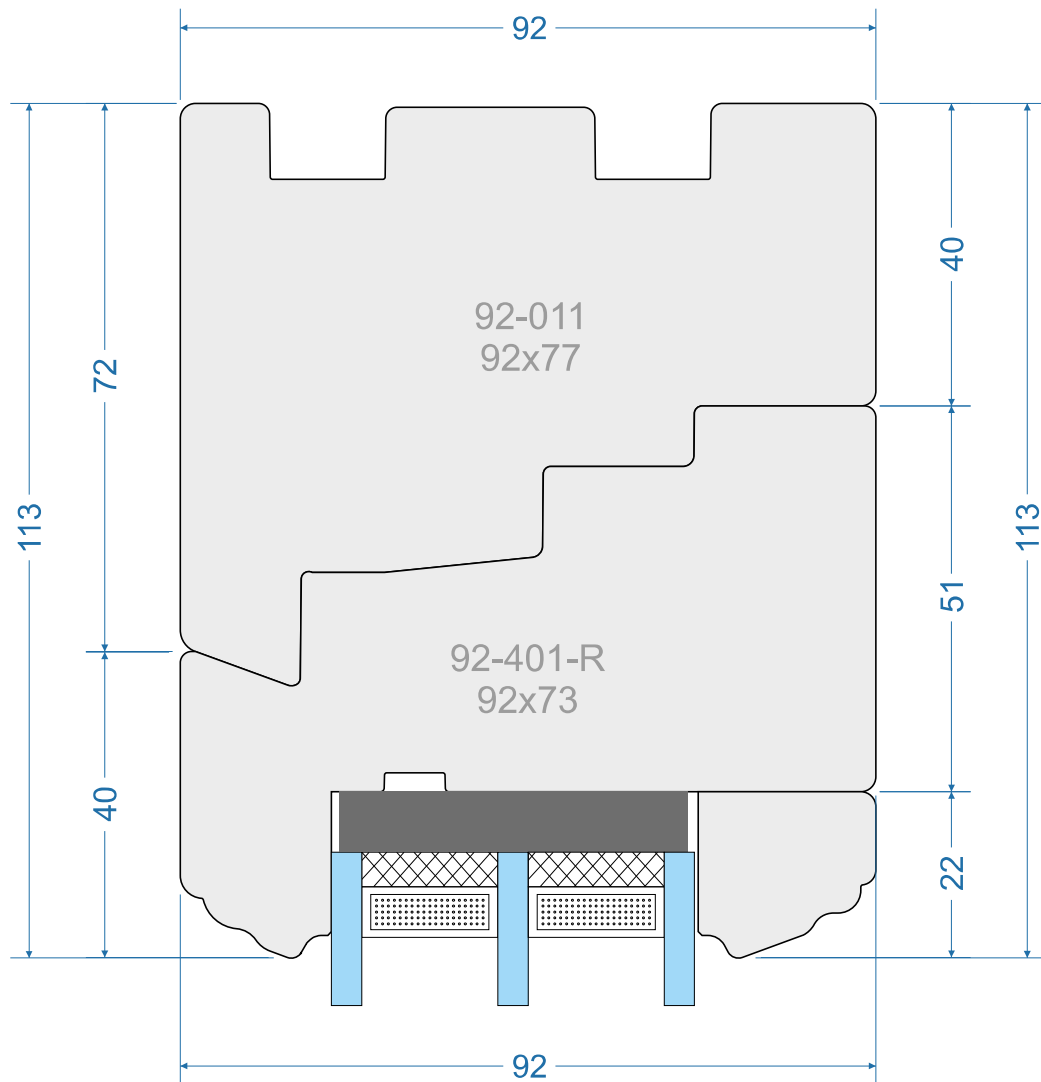

-  Wyrównanie górne
-  Top alignment
-  Alignement supérieur
-  Allineamento superiore
-  Ausrichtung nach oben

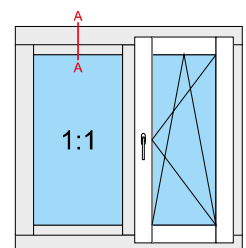

PSV-92-CLS-R-0019

out

in

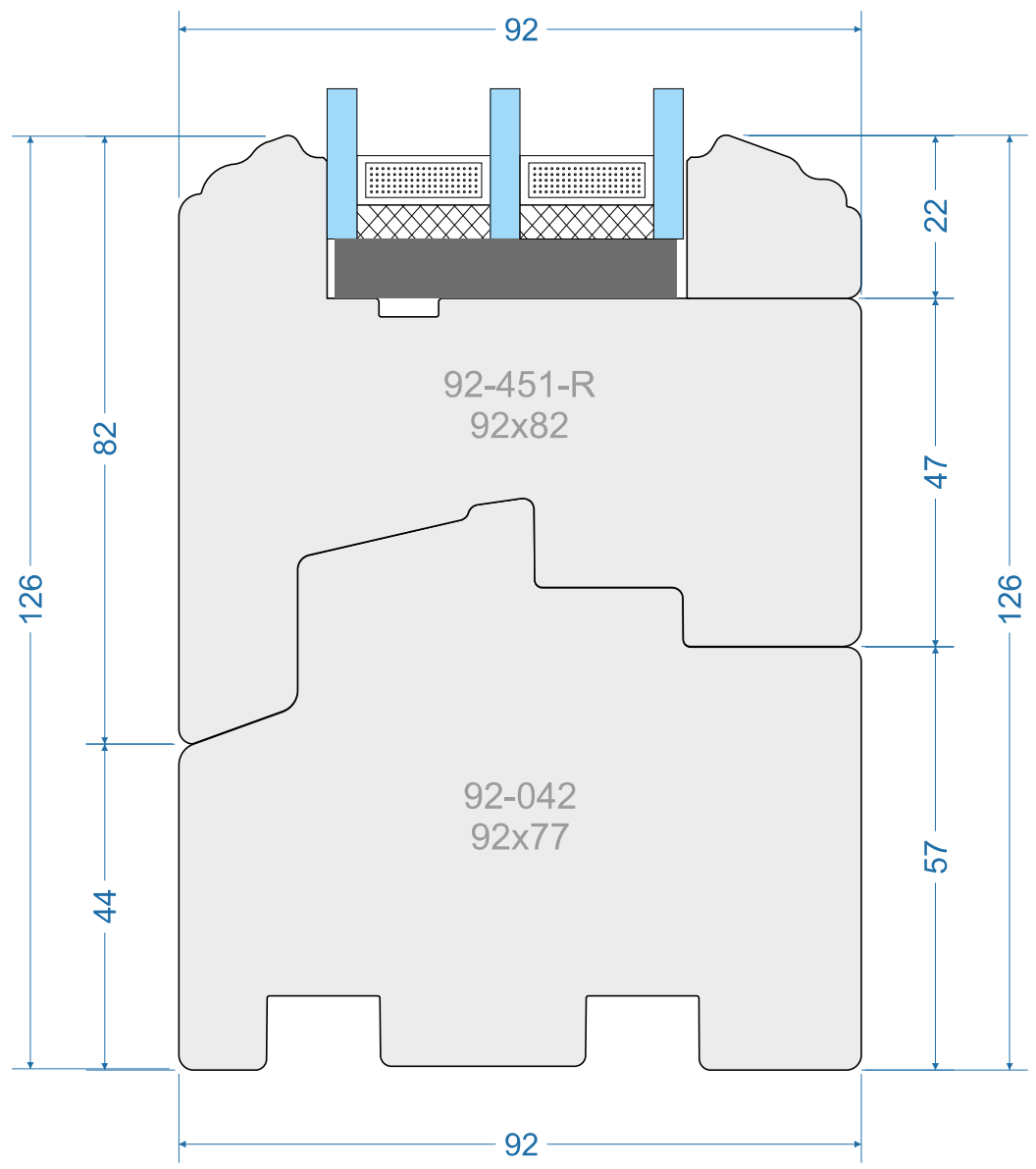



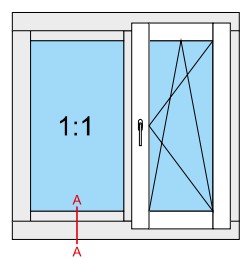



-  Wyrównanie dolne
-  Bottom alignment
-  Alignement en bas
-  Allineamento inferiore
-  Ausrichtung nach unten

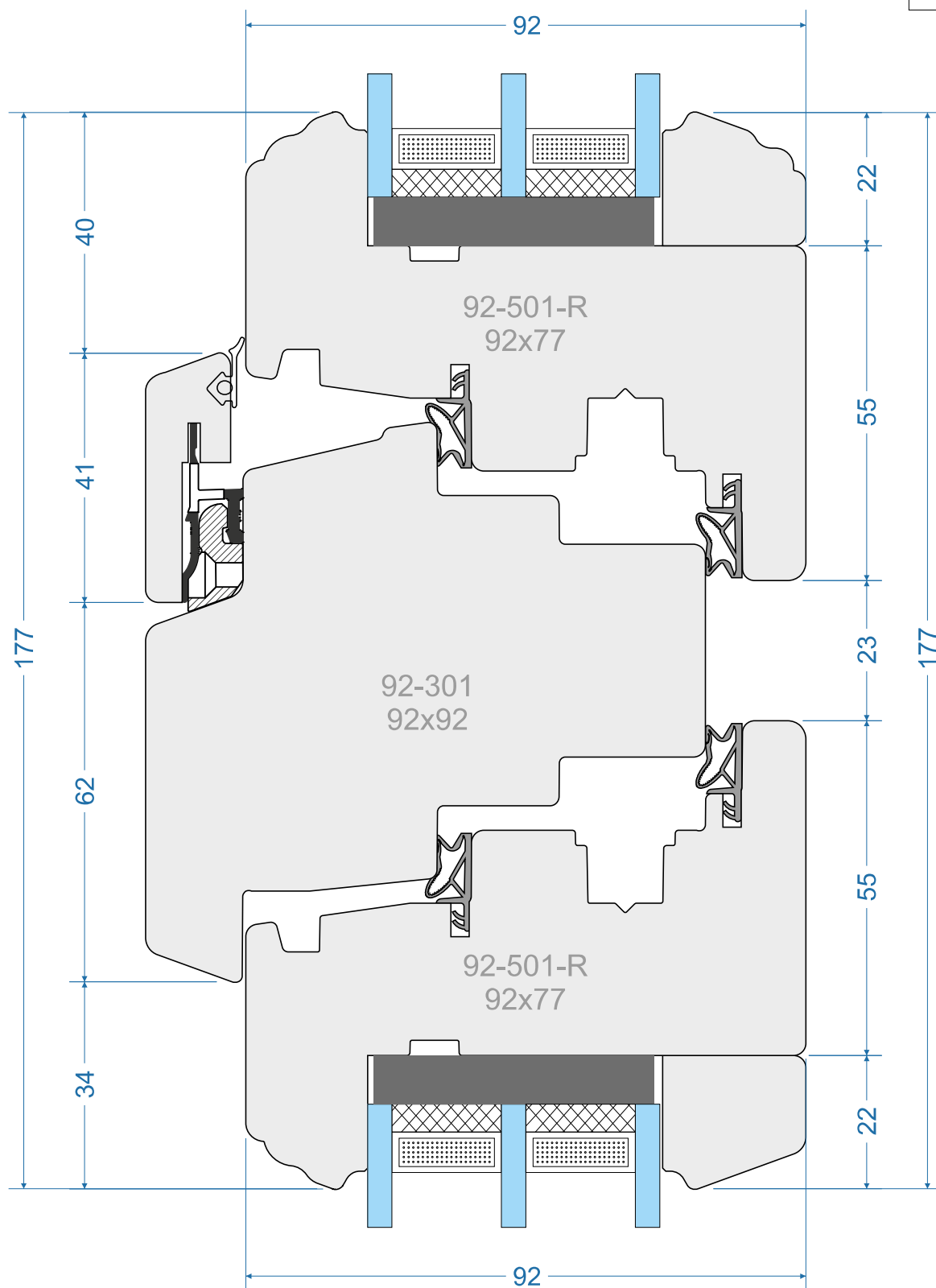

out

in



-  Słupek poziomy - skrzydło + skrzydło
-  Horizontal post - sash + sash
-  Traverse - ouvrant + ouvrant
-  Montante orizzontale - anta + anta
-  Horizontaler Pfosten - Flügel + Flügel

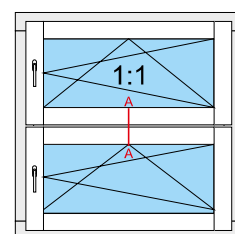



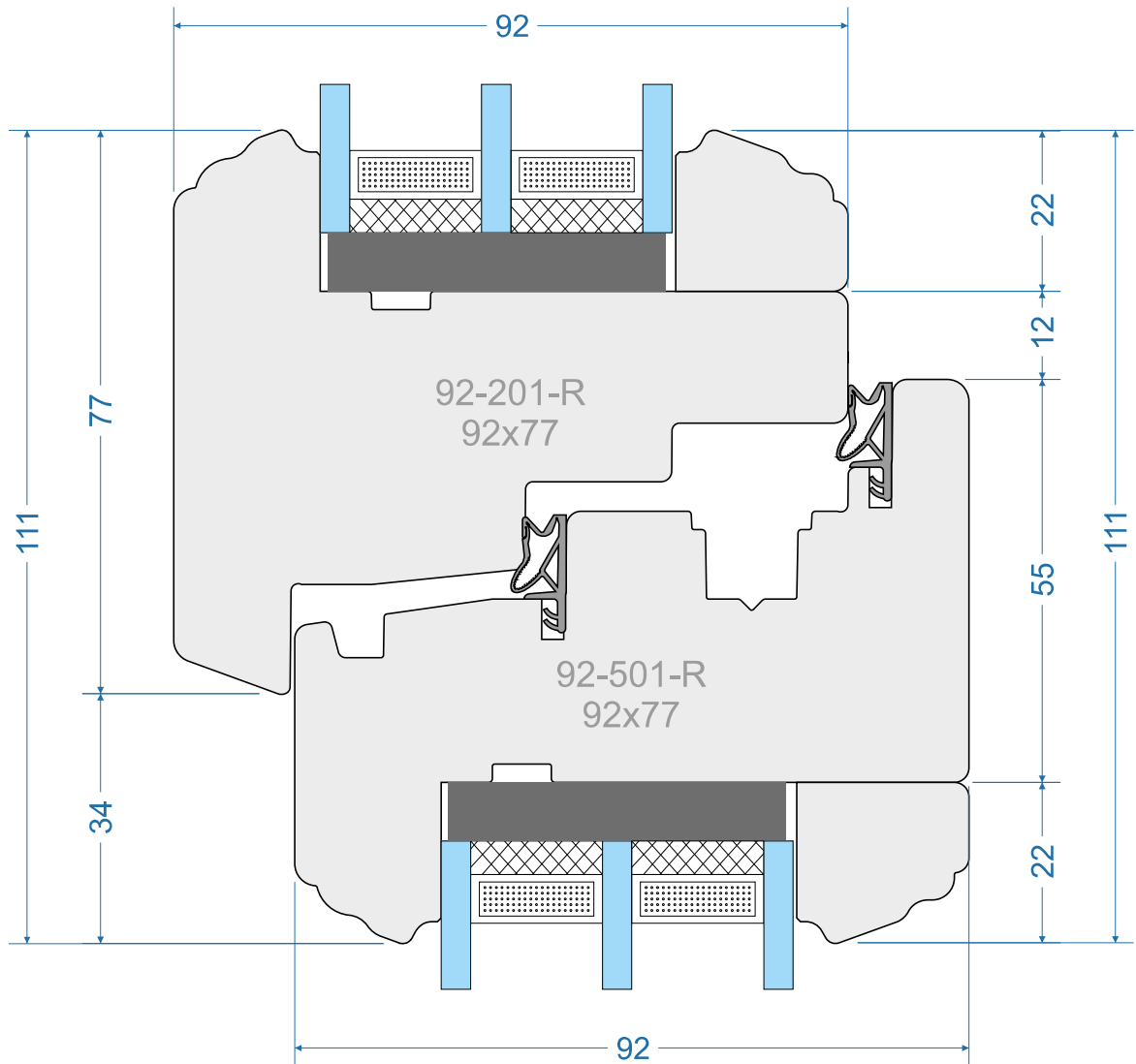

PSV-92-CLS-R-0021

out

in



-  Słupek poziomy - fix + skrzydło
-  Horizontal post - fix + sash
-  Traverse - fixe + ouvrant
-  Montante orizzontale - fisso + anta
-  Horizontaler Pfosten - Fix + Flügel

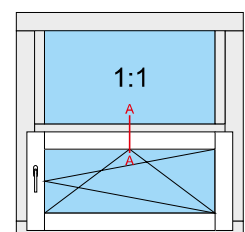



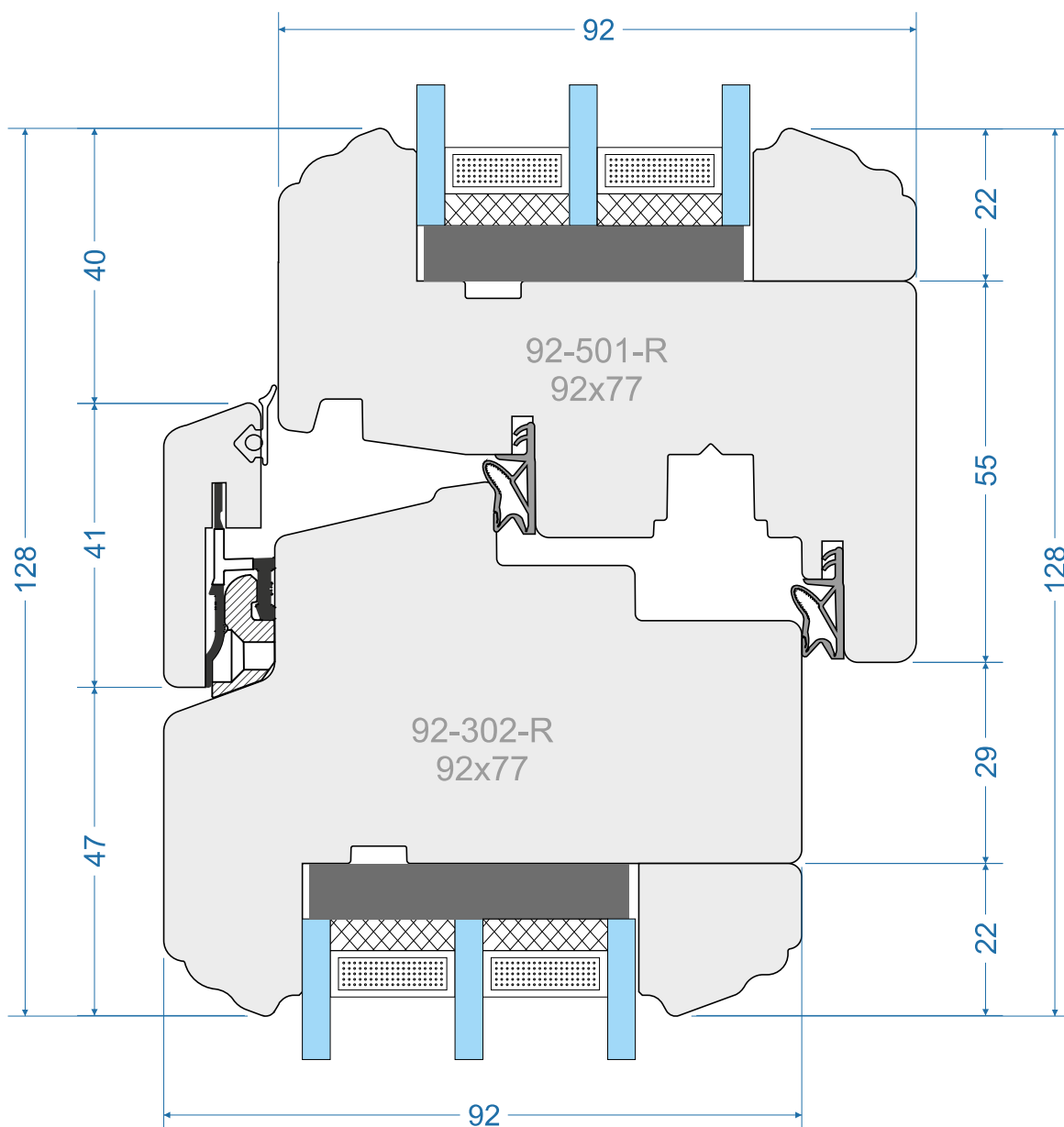

PSV-92-CLS-R-0022

out

in



-  Słupek poziomy - skrzydło + fix
-  Horizontal post - sash + fix
-  Traverse- ouvrant + fixe
-  Montante orizzontale - anta + fisso
-  Horizontaler Pfosten - Flügel + Fix

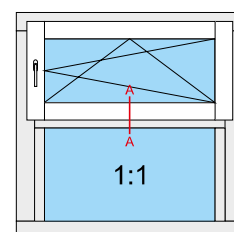

PSV-92-CLS-R-0023

out

in

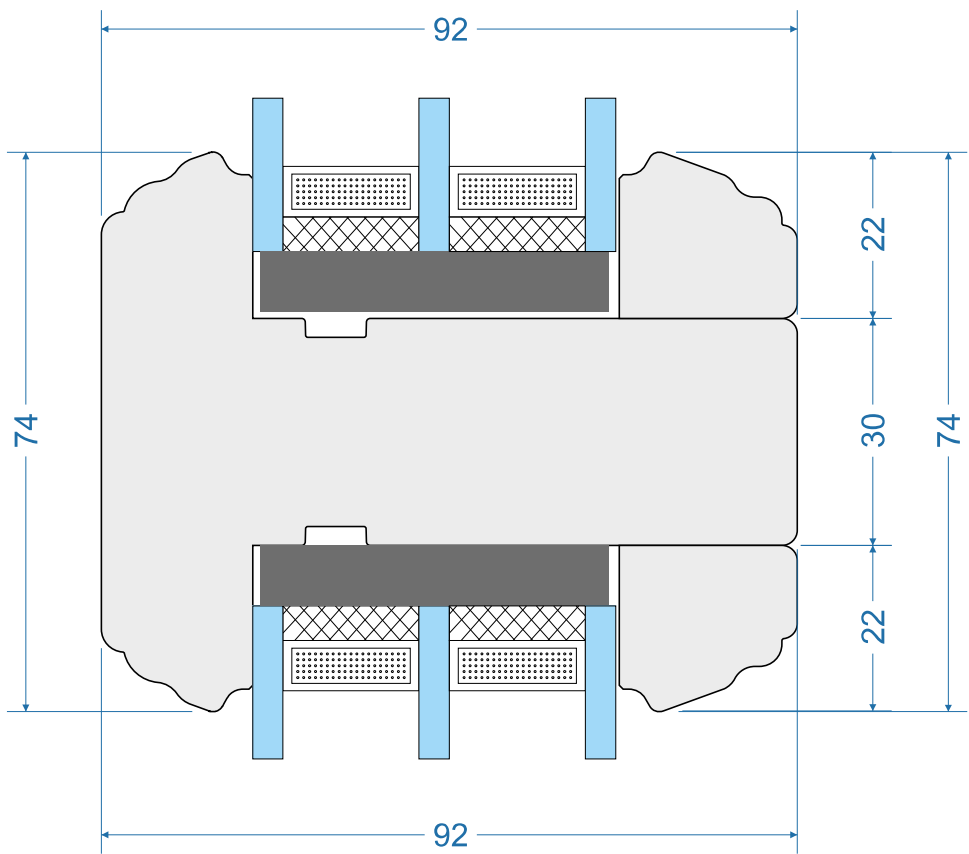



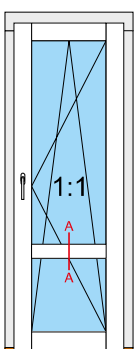



-  Poprzeczka
-  Bar
-  Traversine
-  Traverso
-  Bar

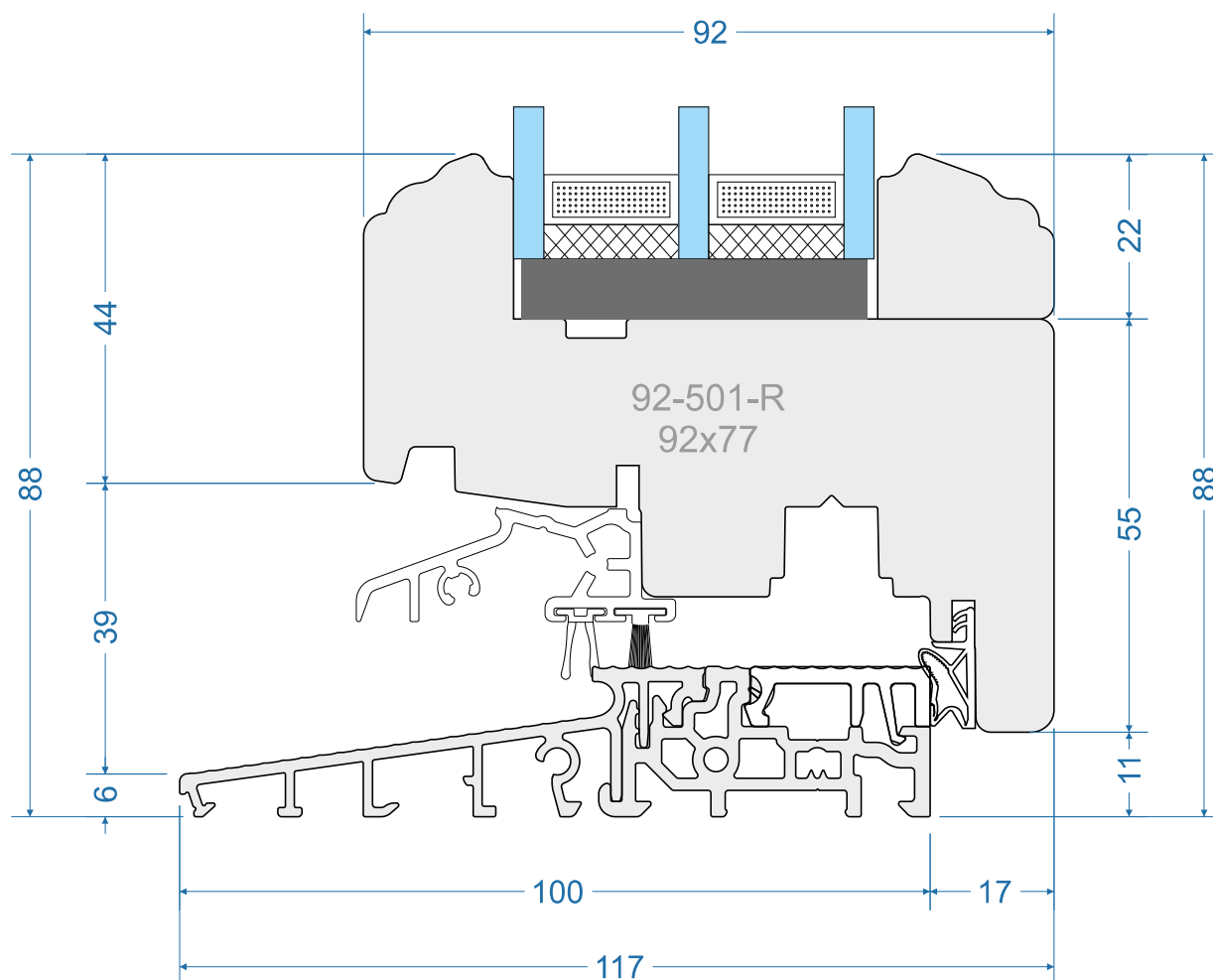

out

in



-  Próg aluminiowy + skrzydło 77mm
-  Aluminum threshold + sash 77mm
-  Seuil en aluminium + châssis 77mm
-  Soglia in alluminio + anta 77mm
-  Aluminiumschwelle + Flügel 77mm



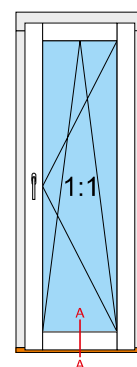

PSV-92-CLS-R-0025

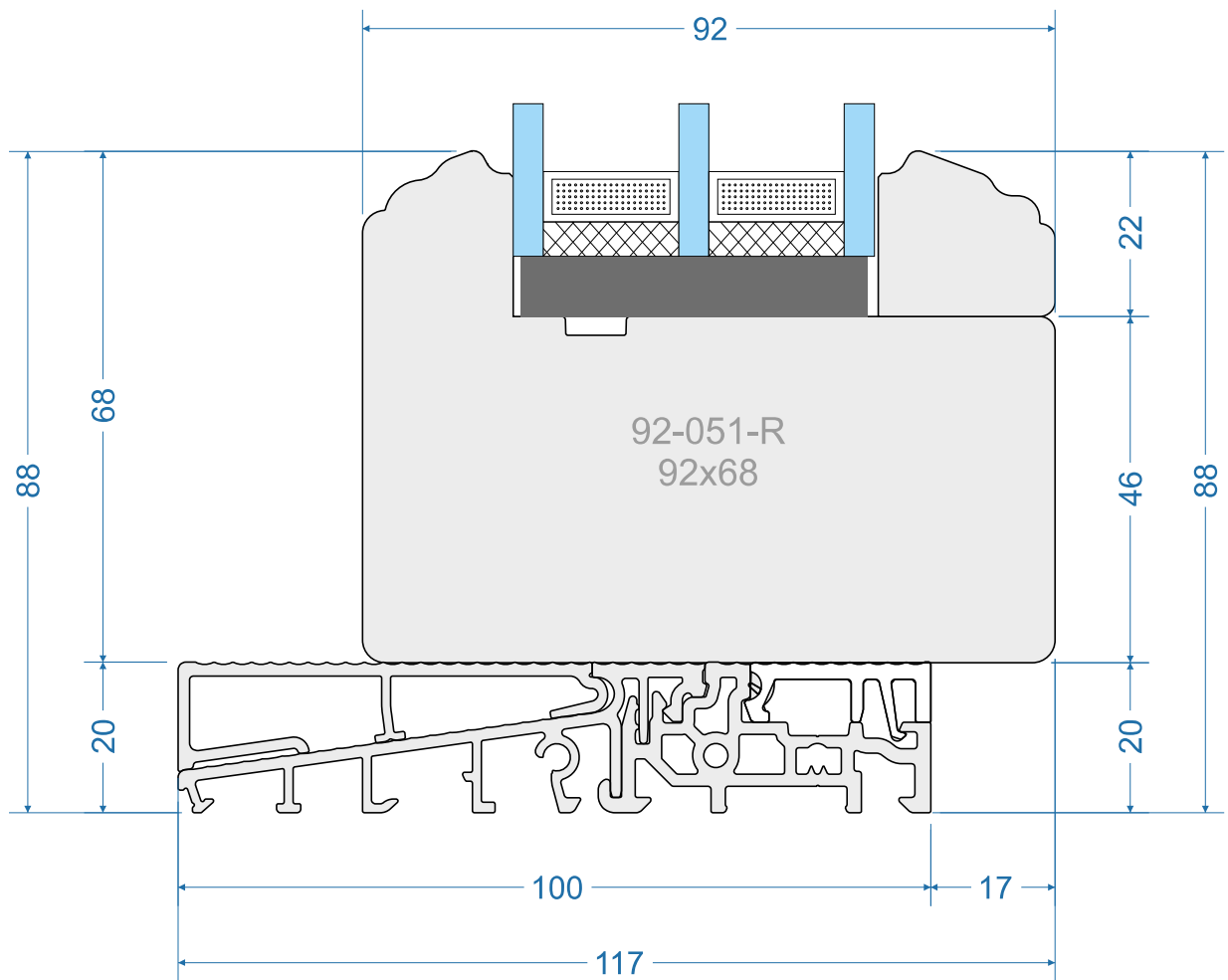

out

in



-  Wyrównanie do „Próg aluminiowy + skrzydło 77mm”
-  Alignment to „Aluminum threshold + sash 77mm”
-  Alignement sur le „Seuil en aluminium + châssis 77mm”
-  Allineamento alla „Soglia in alluminio + anta 77mm”
-  Ausrichtung an der „Aluminiumschwelle + Flügel 77mm”

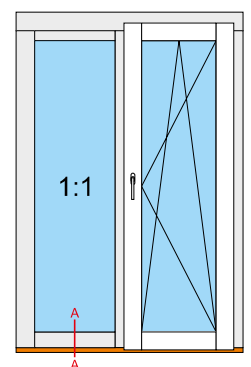



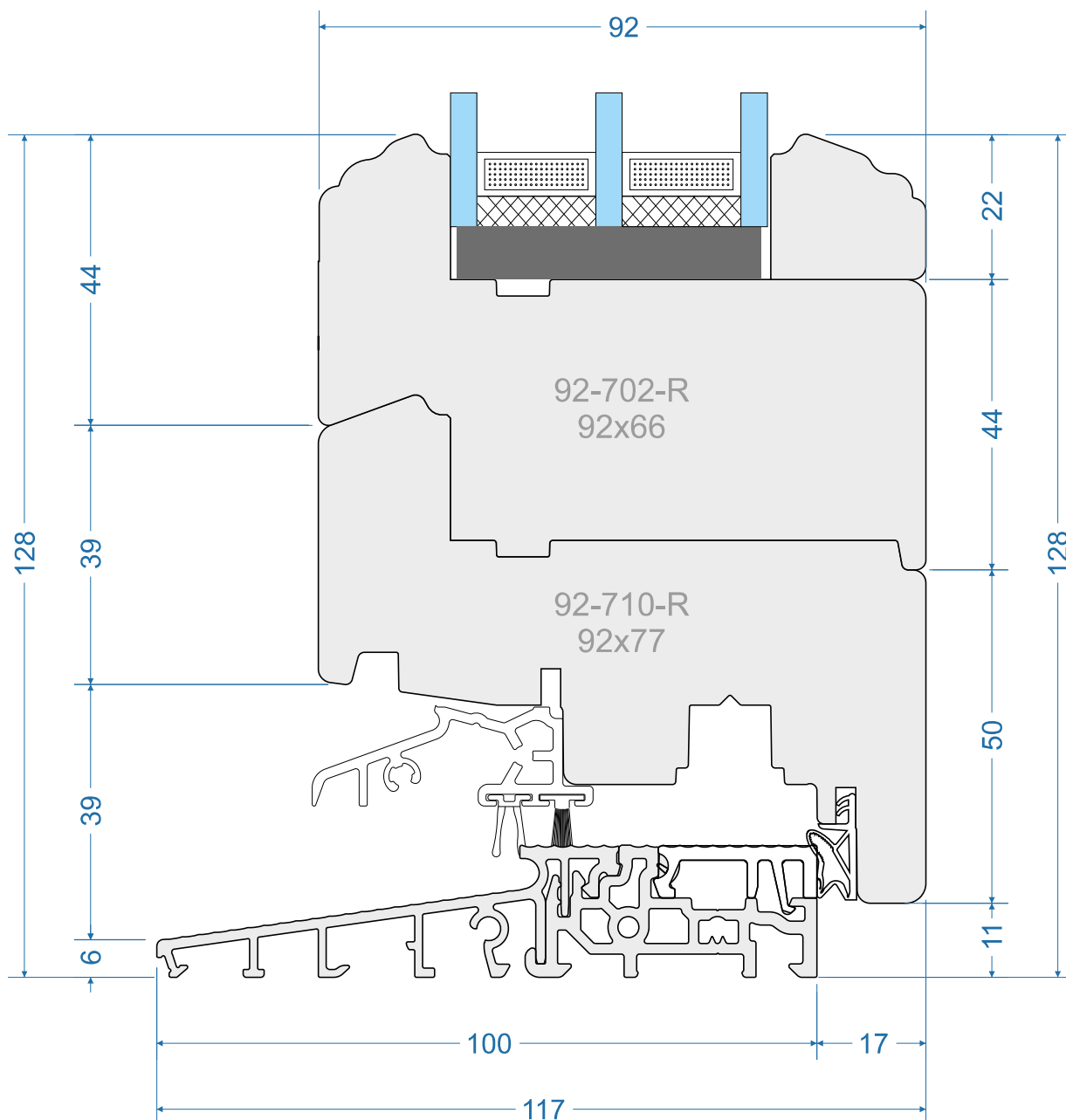

PSV-92-CLS-R-0026

out

in



-  Próg aluminiowy + skrzydło 77mm + cokół 66mm
-  Aluminum threshold + sash 77mm + plinth 66mm
-  Seuil en aluminium + châssis 77mm + socle 66mm
-  Soglia in alluminio + anta 77mm + zoccolo 66mm
-  Aluminiumschwelle + Flügel 77mm + Sockel 66mm



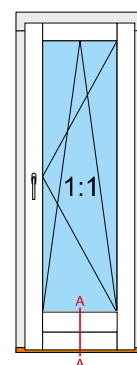

PSV-92-CLS-R-0027

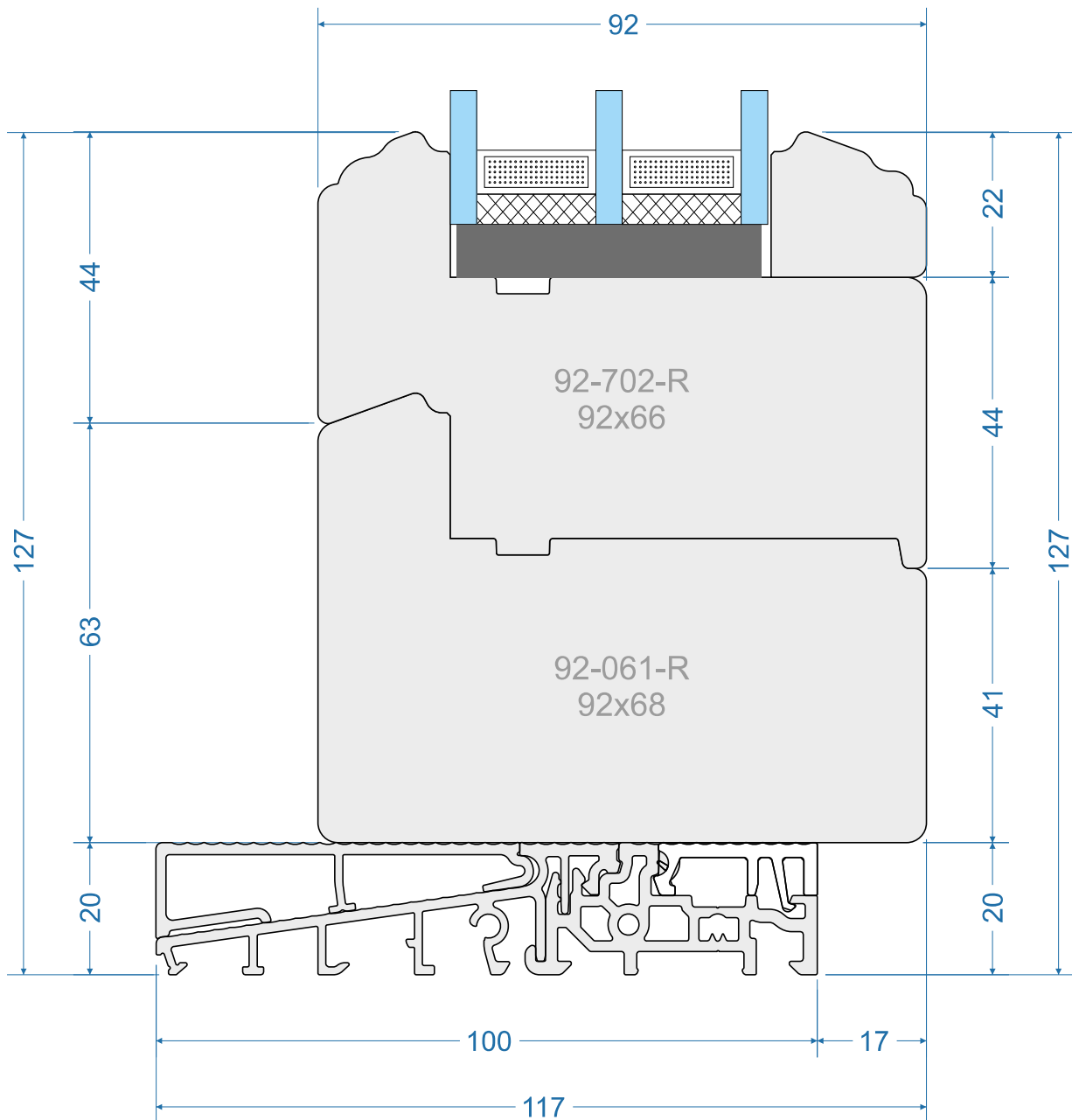

out

in



-  Wyrównanie do „Próg aluminiowy + skrzydło 77mm + cokół 66mm”
-  Alignment to „Aluminum threshold + sash 77mm + plinth 66mm”
-  Alignement sur le „Seuil en aluminium + châssis 77mm + socle 66mm”
-  Allineamento alla „Soglia in alluminio + anta 77mm + zoccolo 66mm”
-  Ausrichtung an der „Aluminiumschwelle + Flügel 77mm + Sockel 66mm”

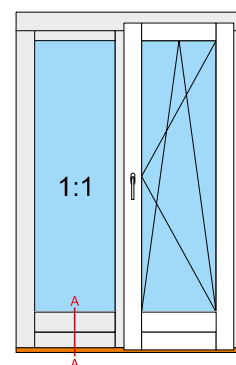



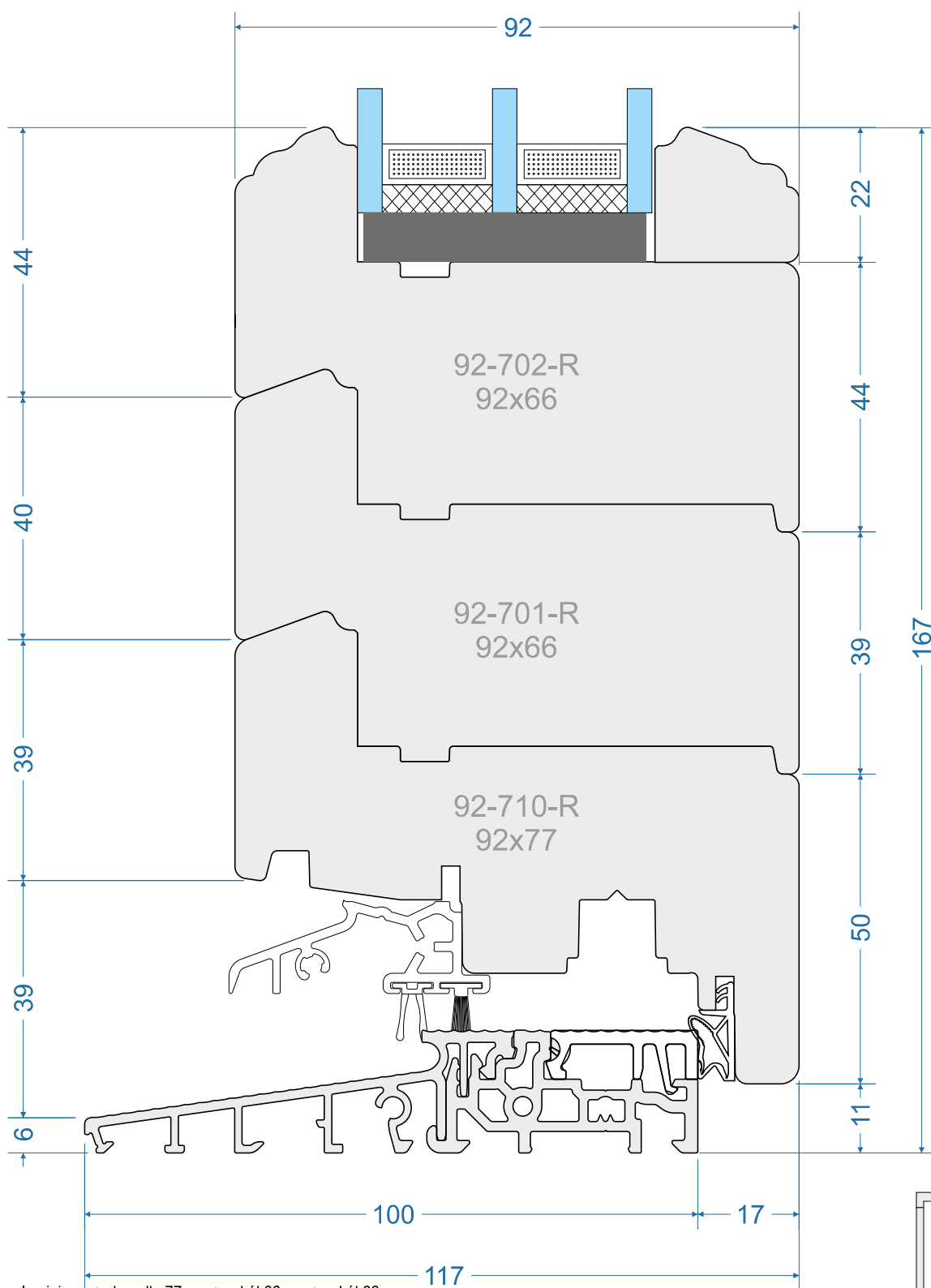

PSV-92-CLS-R-0028

out

in



-  Próg aluminiowy + skrzydło 77mm + cokół 66mm + cokół 66mm
-  Aluminum threshold + sash 77mm + plinth 66mm + plinth 66mm
-  Seuil en aluminium + châssis 77mm + socle 66mm + socle 66mm
-  Soglia in alluminio + anta 77mm + zoccolo 66mm + zoccolo 66mm
-  Aluminiumschwelle + Flügel 77mm + Sockel 66mm + Sockel 66mm



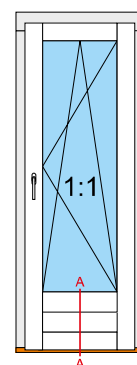

PSV-92-CLS-R-0029

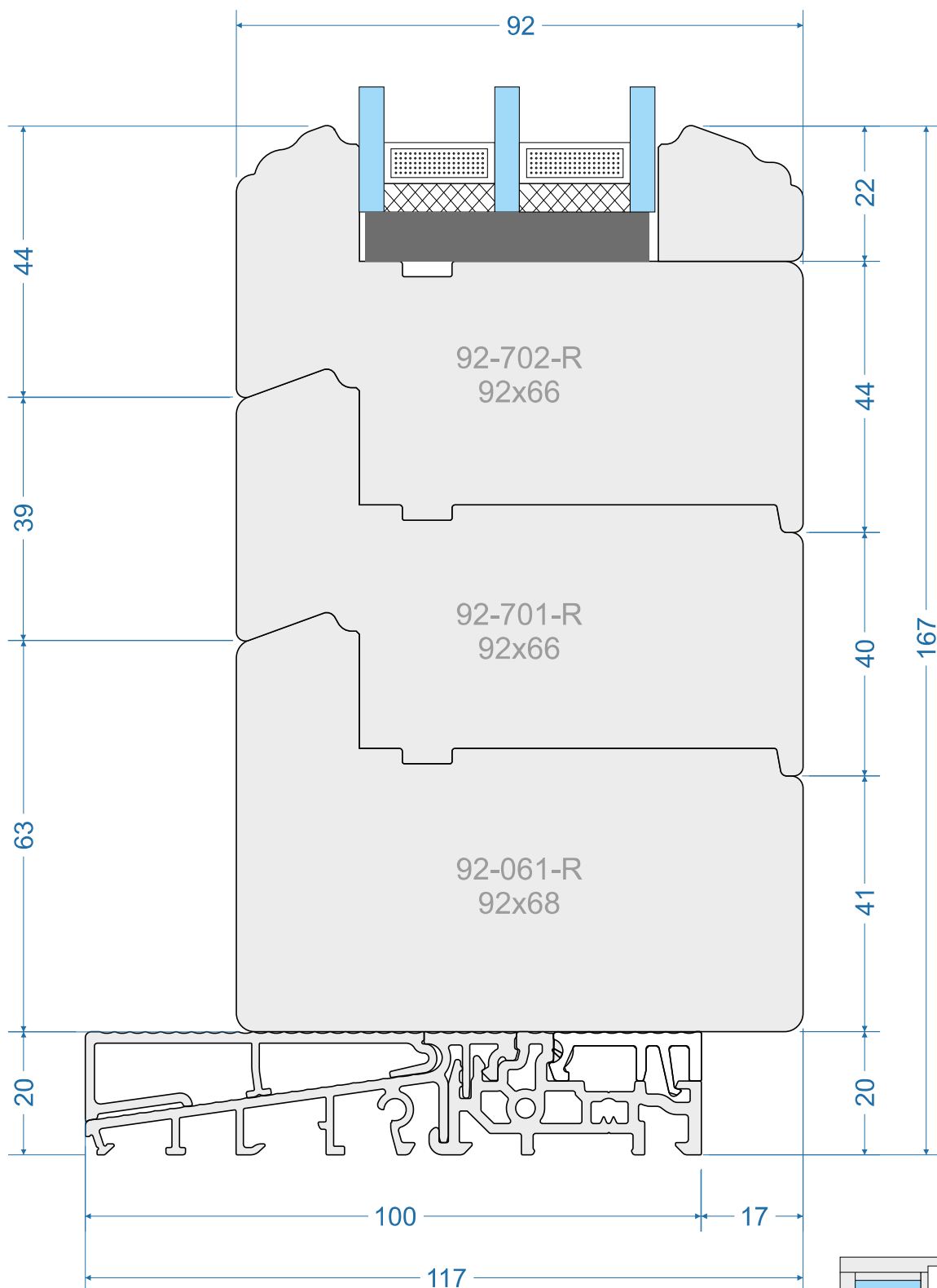

out

in



-  Wyrównanie do „Próg aluminiowy + skrzydło 77mm + cokół 66mm + cokół 66mm”
-  Alignment to „Aluminum threshold + sash 77mm + plinth 66mm + plinth 66mm”
-  Alignement sur le „Seuil en aluminium + châssis 77mm + socle 66mm + socle 66mm”
-  Allineamento alla „Soglia in alluminio + anta 77mm + zoccolo 66mm + zoccolo 66mm”
-  Ausrichtung an der „Aluminiumschwelle + Flügel 77mm + Sockel 66mm + Sockel 66mm”

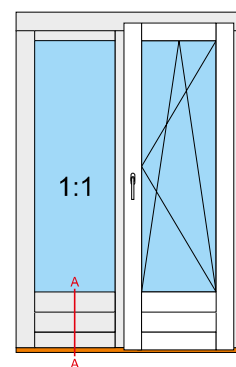



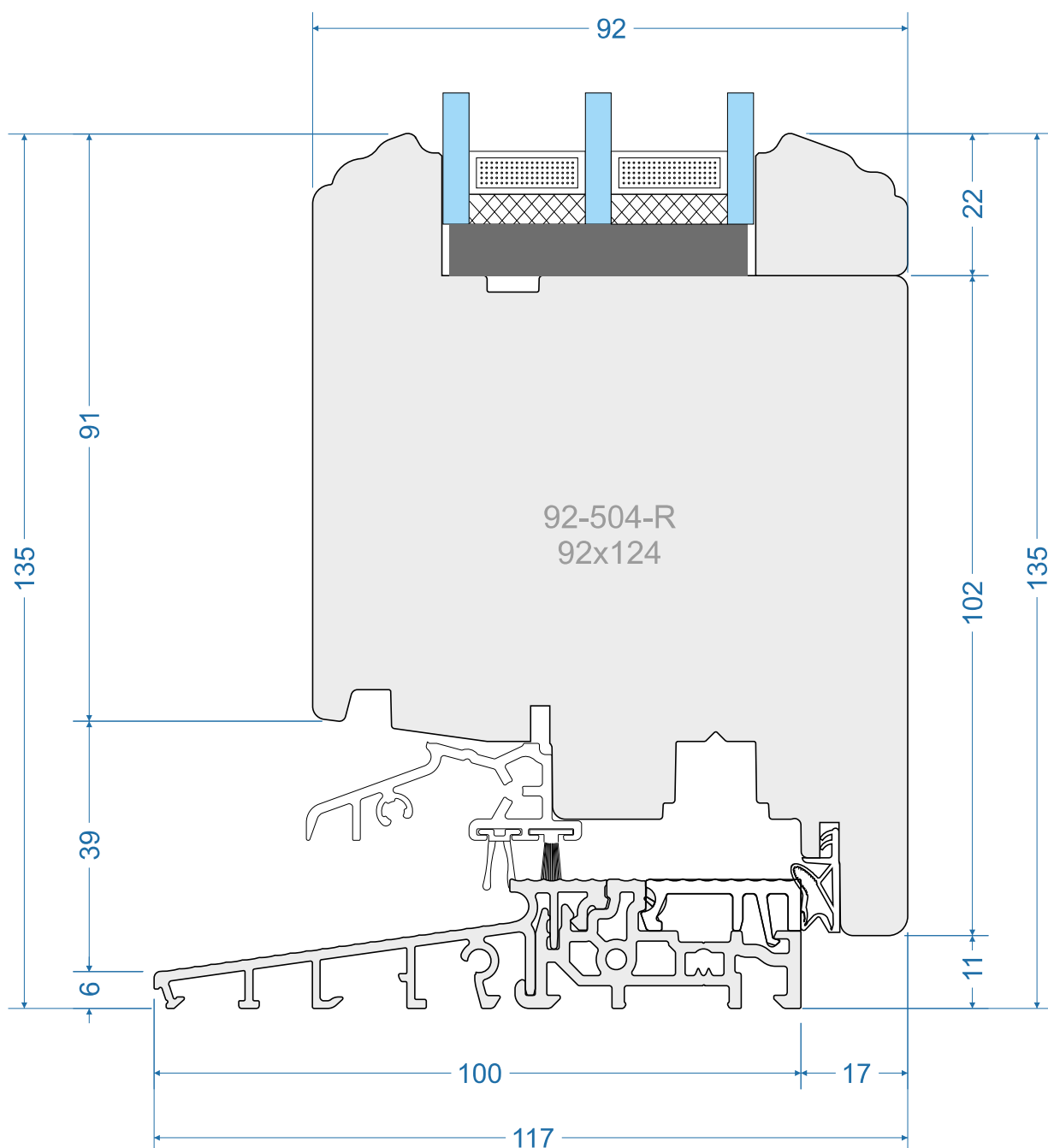

PSV-92-CLS-R-0030

out

in



-  Próg aluminiowy + skrzydło 124mm
-  Aluminum threshold + sash 124mm
-  Seuil en aluminium + ouvrant 124mm
-  Soglia in alluminio + anta 124mm
-  Aluminiumschwelle + Flügel 124mm



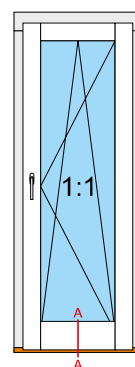

PSV-92-CLS-R-0031

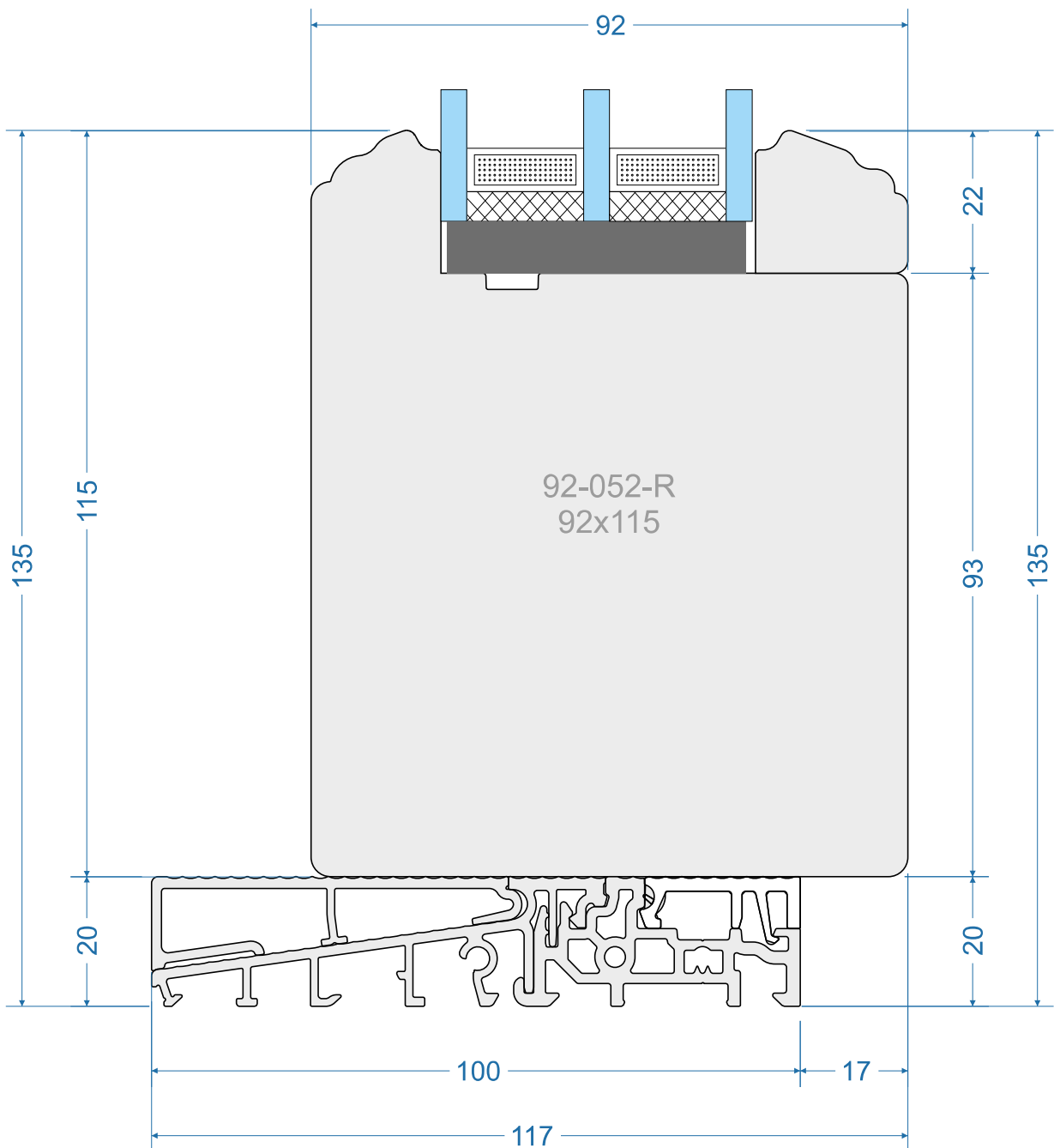

out

in



-  Wyrównanie do „Próg aluminiowy + skrzydło 124mm”
-  Alignment to „Aluminum threshold + sash 124mm”
-  Alignement sur le „Seuil en aluminium + ouvrant 124mm”
-  Allineamento alla „Soglia in alluminio + anta 124mm”
-  Ausrichtung an der „Aluminiumschwelle + Flügel 124mm”



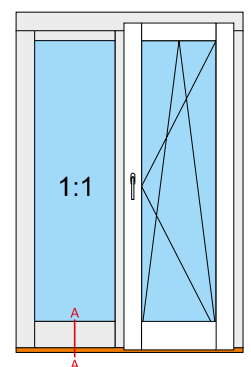

PSV-92-CLS-R-0032

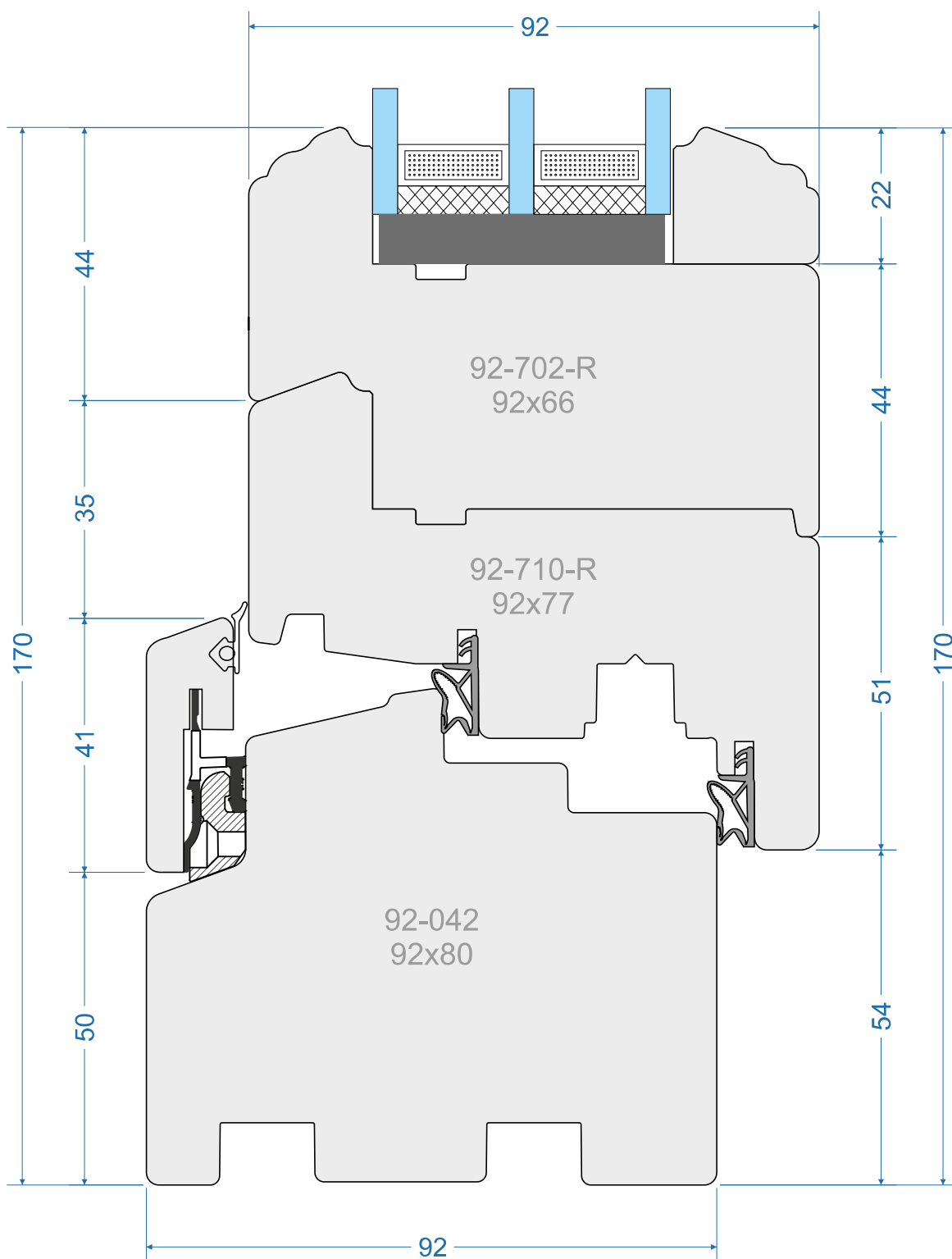

out

in



-  Rama + skrzydło 77mm + cokół 66mm
-  Frame + sash 77mm + plinth 66mm
-  Cadre + châssis 77mm + socle 66mm
-  Telaio + anta 77mm + zoccolo 66mm
-  Rahmen + Flügel 77mm + Sockel 66mm



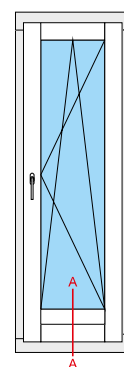

PSV-92-CLS-R-0033

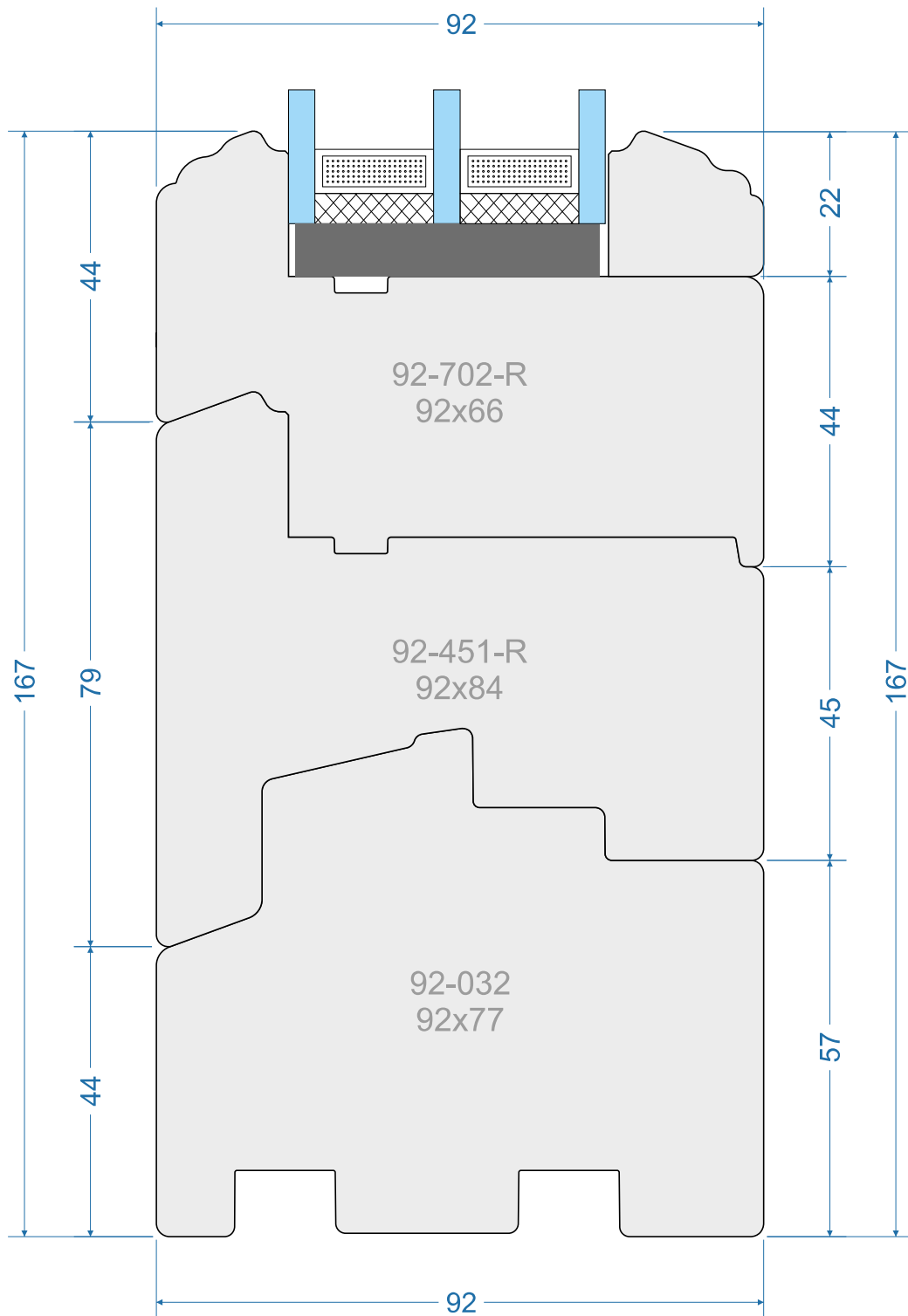

out

in



-  Wyrównanie do „Rama + skrzydło 77mm + cokół 66mm”
-  Alignment to „Frame + sash 77mm + plinth 66mm”
-  Alignement sur le „Cadre + châssis 77mm + socle 66mm”
-  Allineamento alla „Telaio + anta 77mm + zoccolo 66mm”
-  Ausrichtung an der „Rahmen + Flügel 77mm + Sockel 66mm”

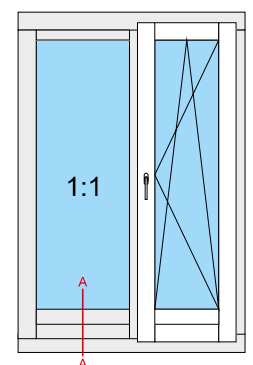

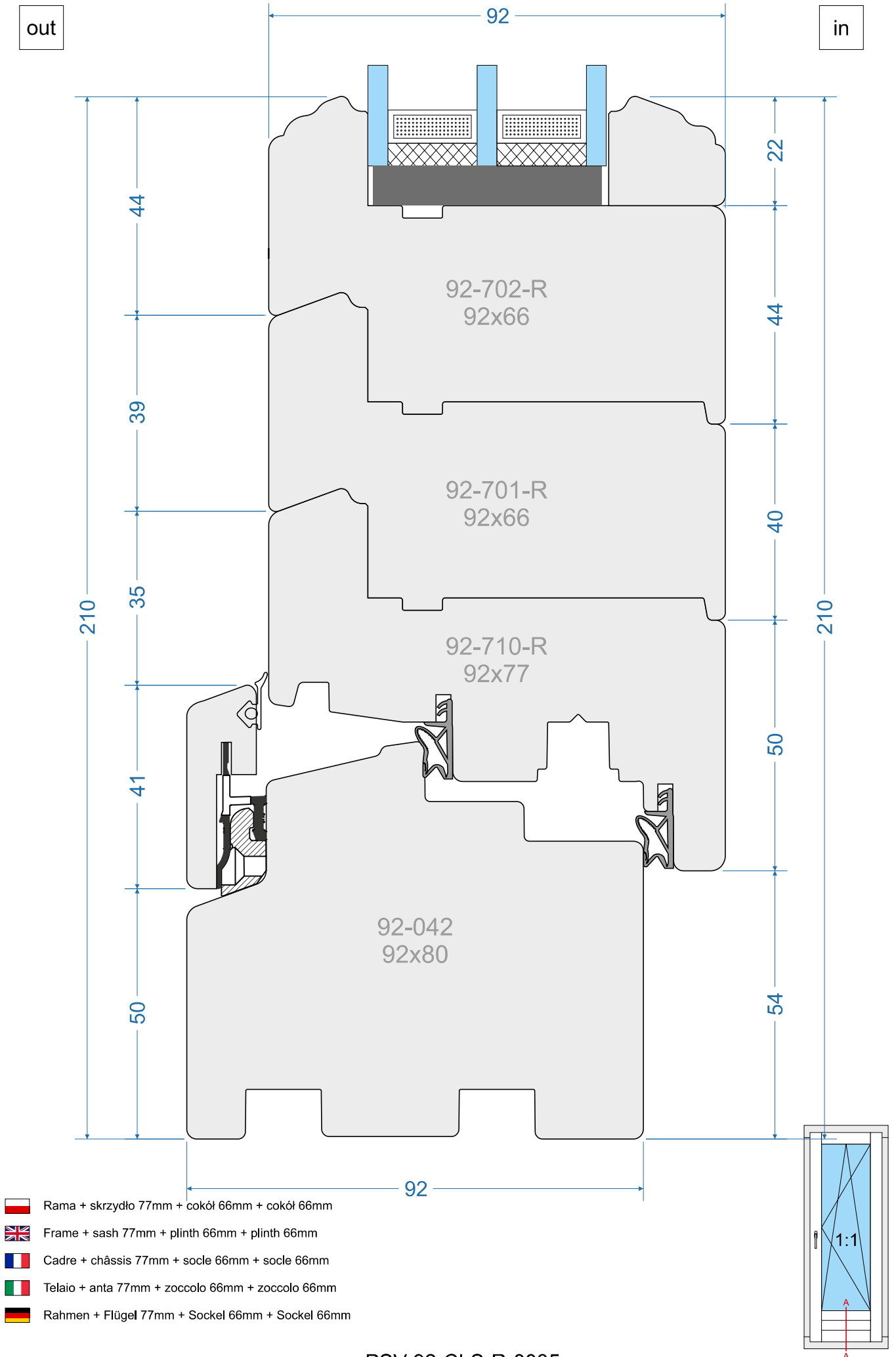



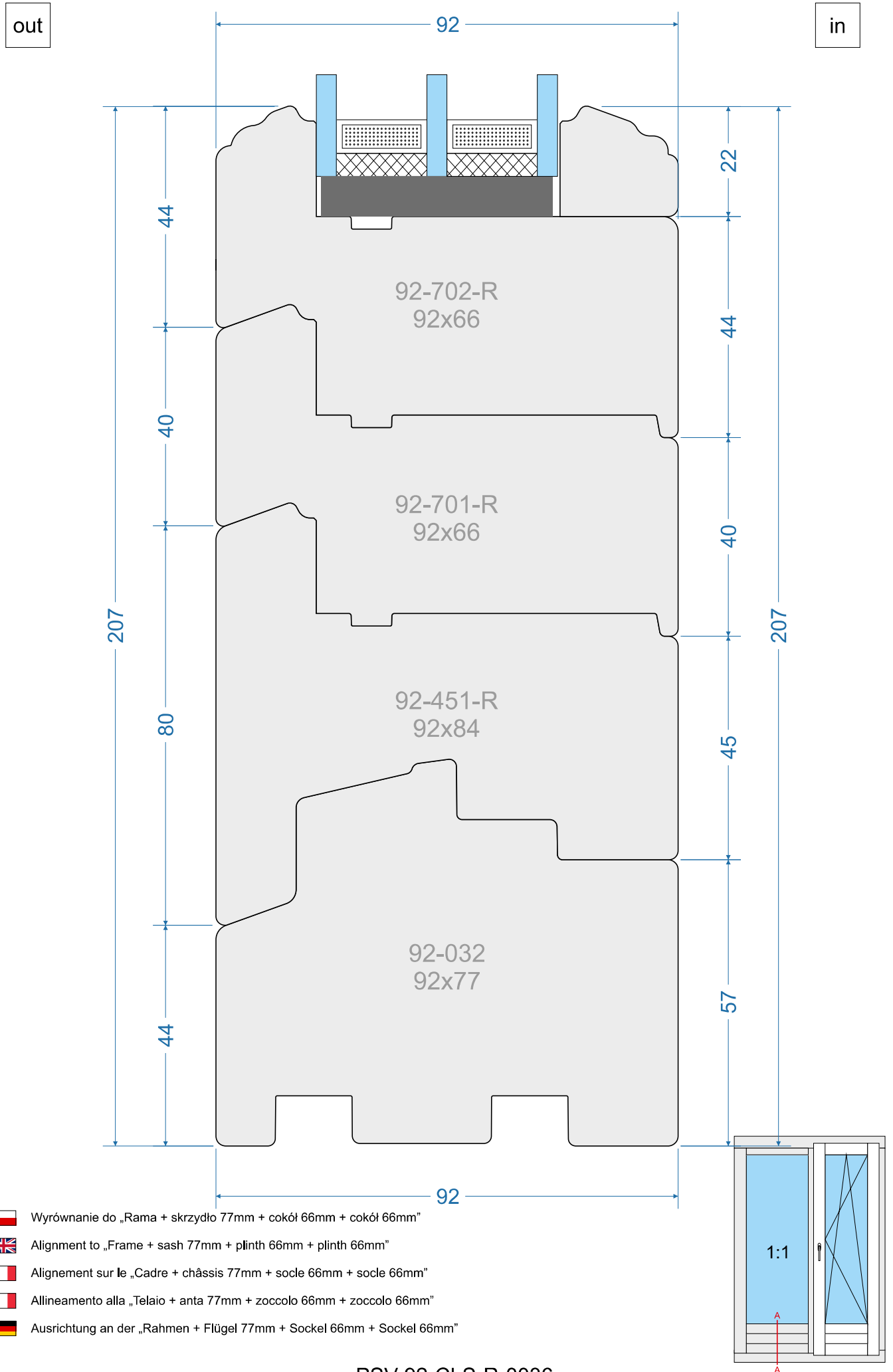

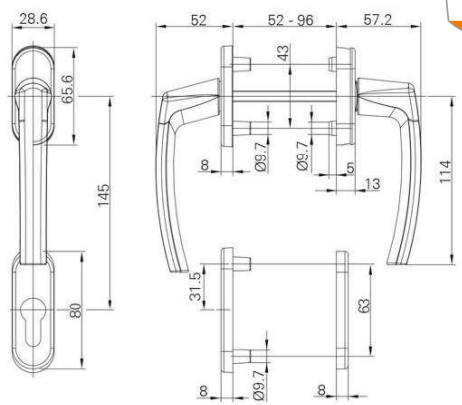
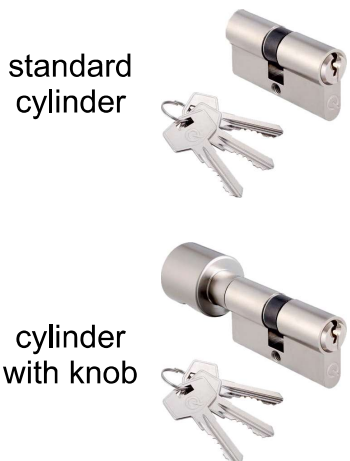
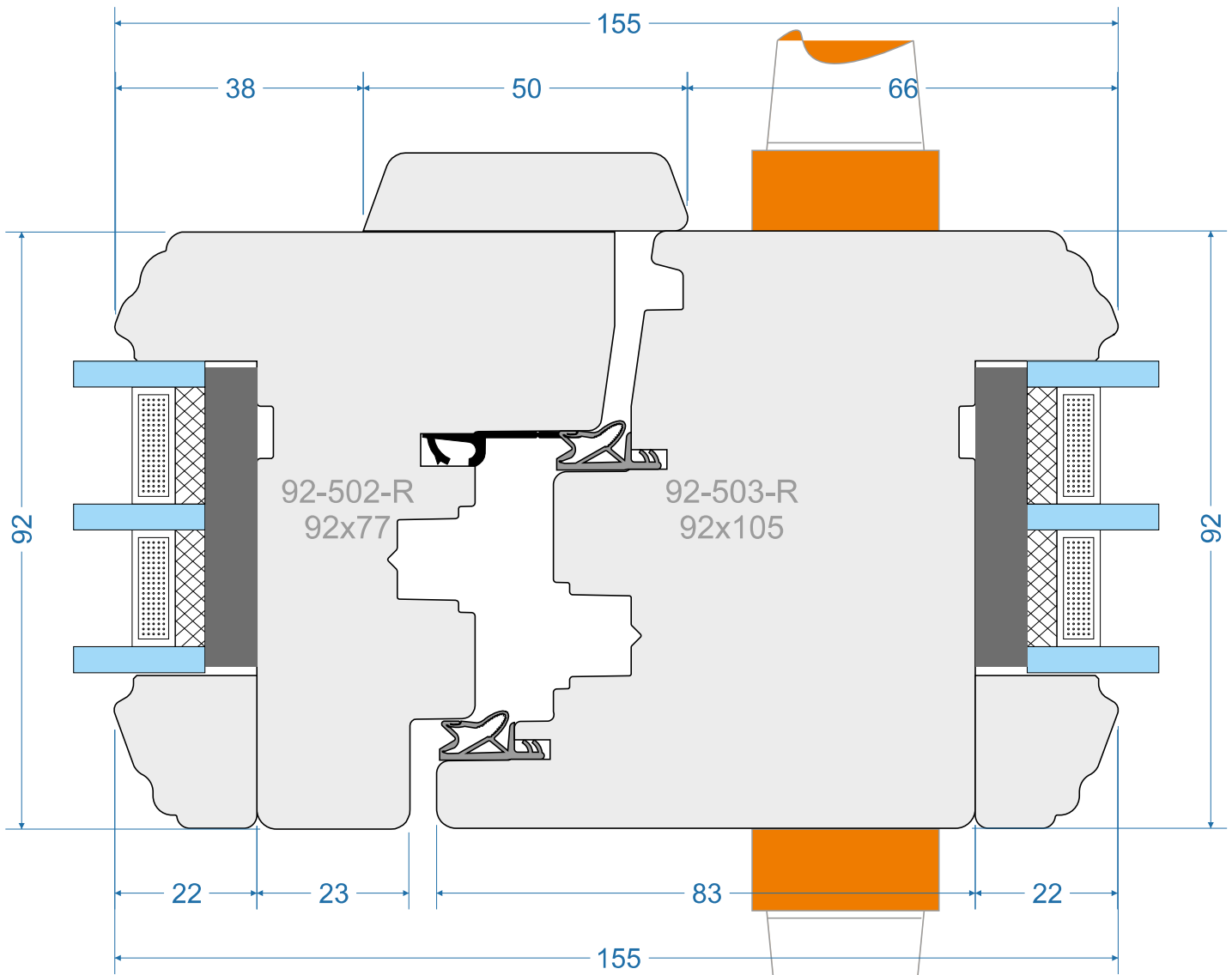
PSV-92-CLS-R-0035





-  Dwustronna klamka okienna
-  Double side window type handle
-  Poignée de fenêtre double face
-  Maniglia bifacciale per finestre
-  Doppelseitiger Fenster Griff

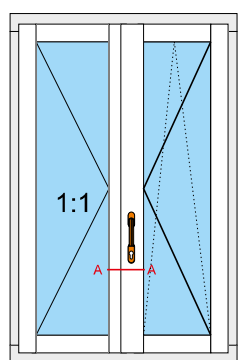

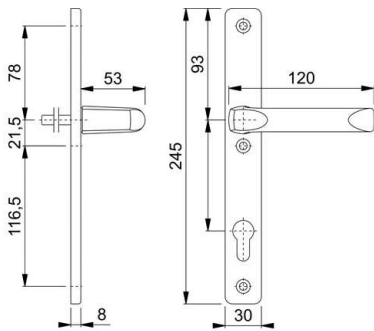
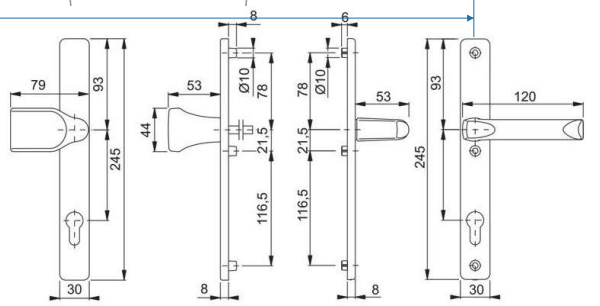
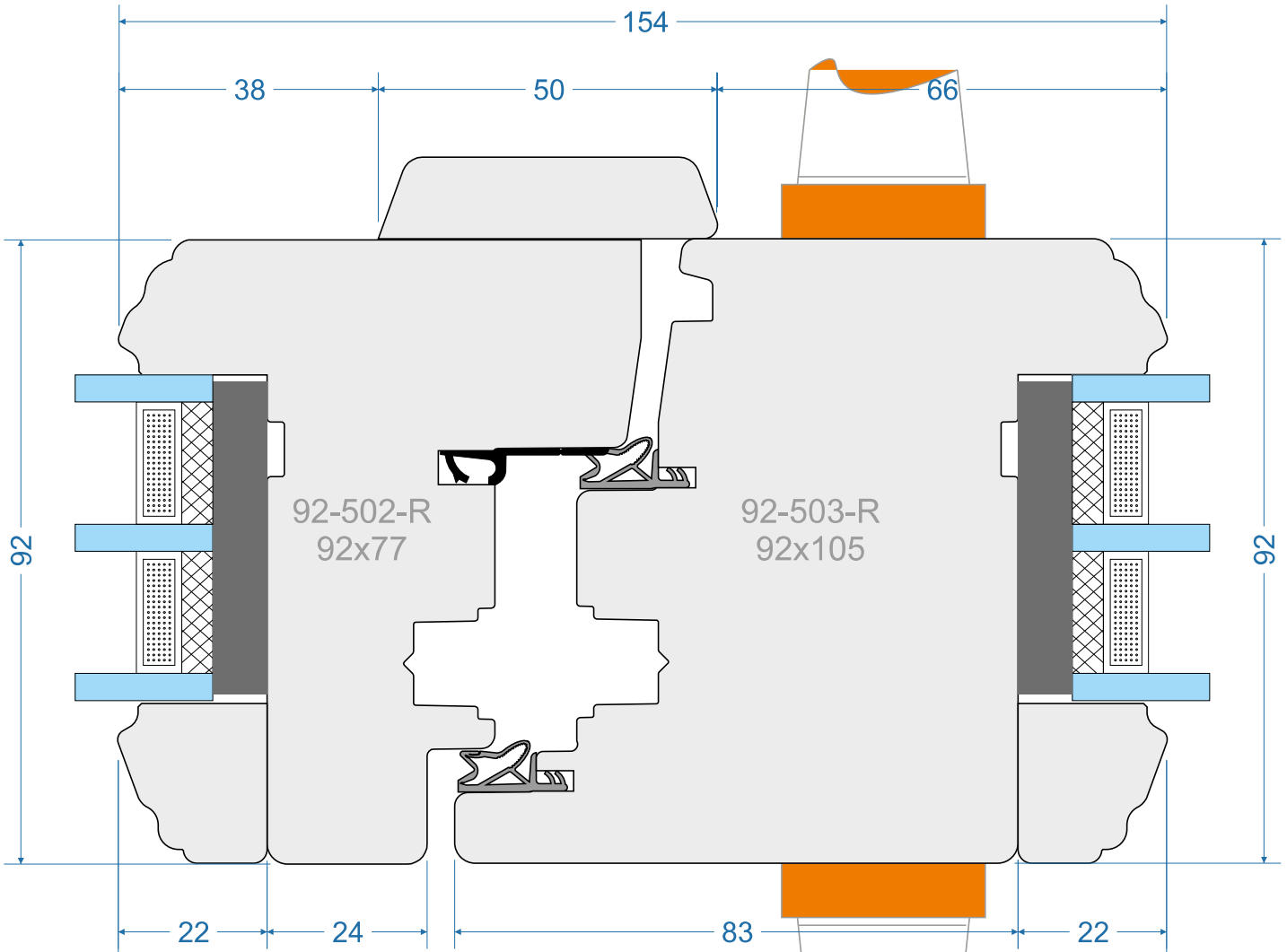





standard cylinder



cylinder with knob



-  Dwustronna klamka drzewiowa
-  Double side door type handle
-  Poignée de Porte Fenêtre double face
-  Maniglia bifacciale per porte finestra
-  Doppelseitiger Tür Griff

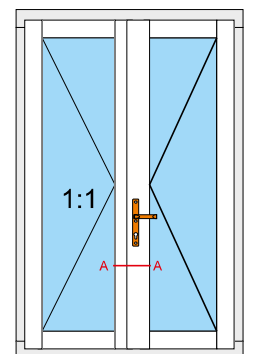





out

in

max 138

min 40

12

-  Górne poszerzenie ramy
-  Upper frame extension
-  Élargissement supérieur du cadre
-  Estensione del telaio superiore
-  Obere Rahmenverbreitung

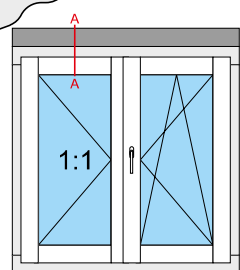
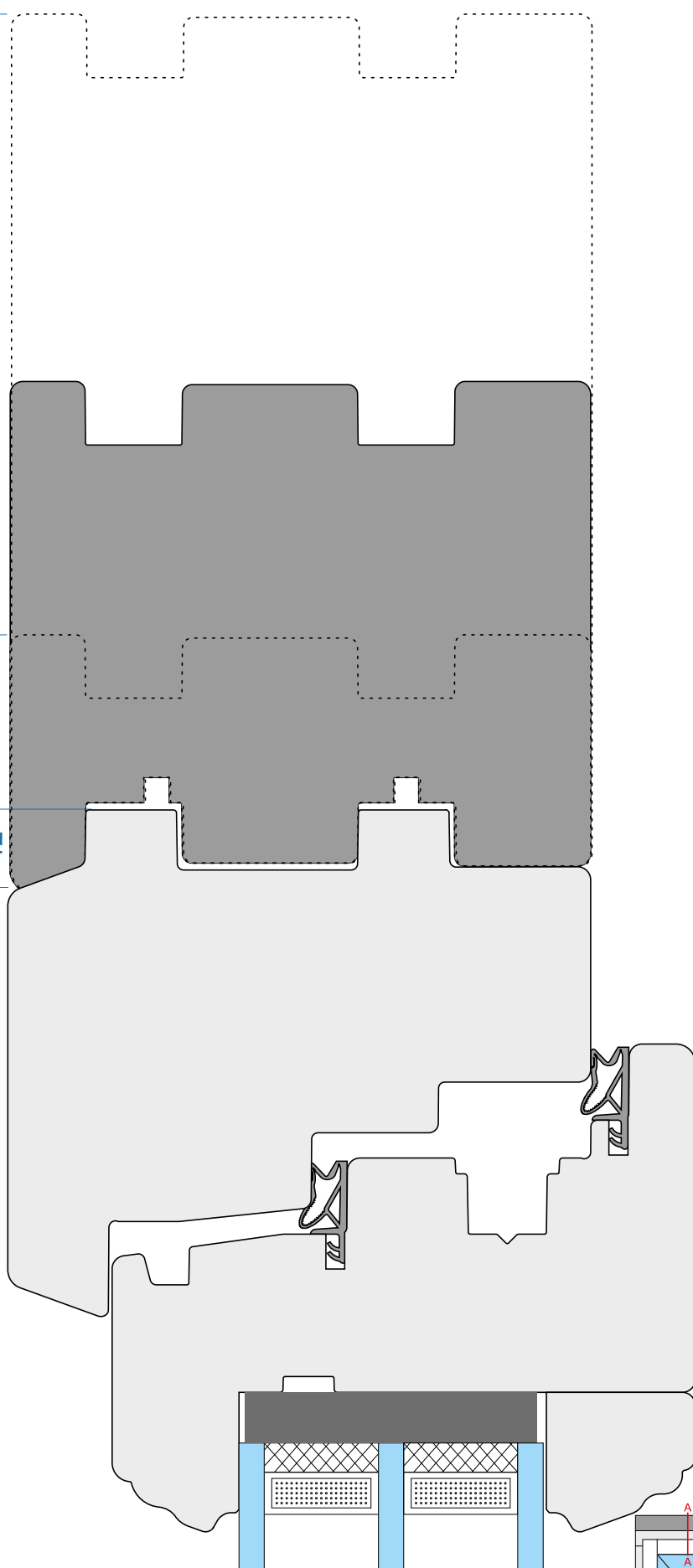



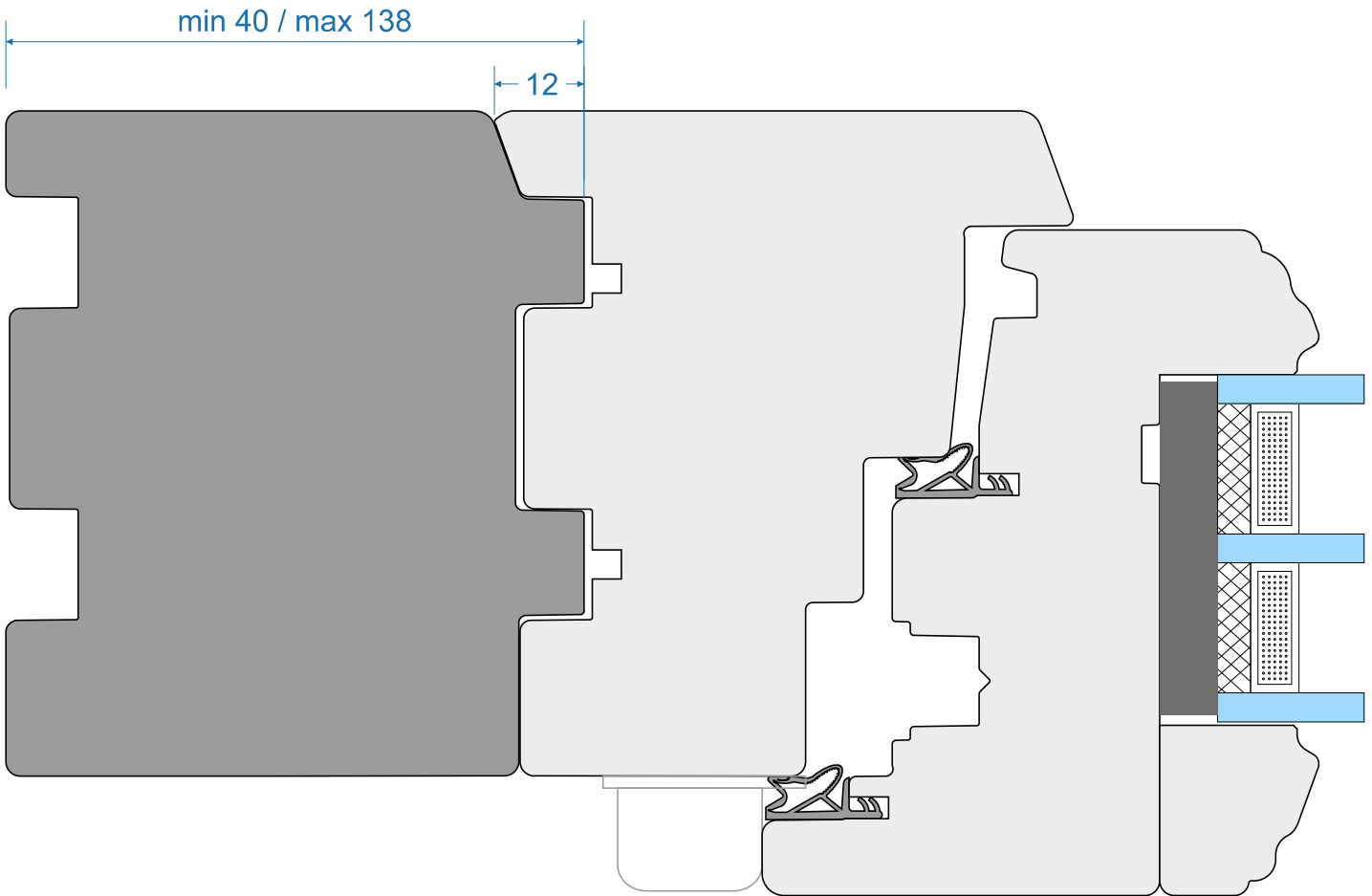

PSV-92-CLS-R-0039

out



in



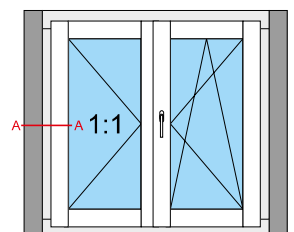

-  Boczne poszerzenie ramy
-  Side frame extension
-  Élargissement latéral du cadre
-  Estensione del telaio laterale
-  Seitliche Rahmenverbreitung

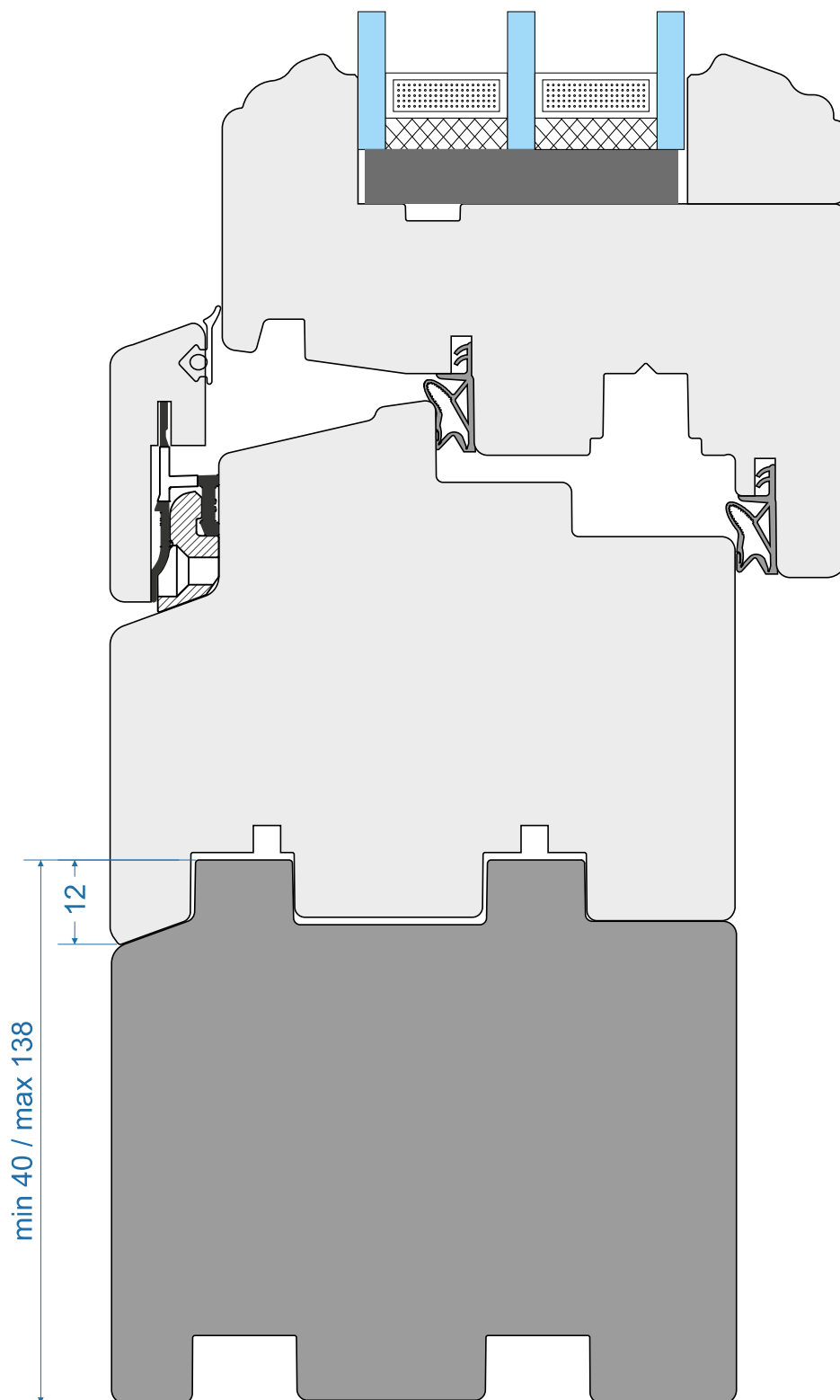

out

in





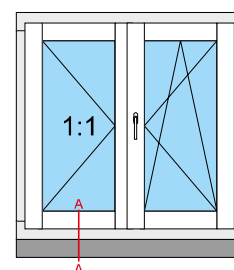

-  Dolne poszerzenie ramy
-  Lower frame extension
-  Élargissement inférieure du cadre
-  Estensione del telaio inferiore
-  Untere Rahmenverbreitung

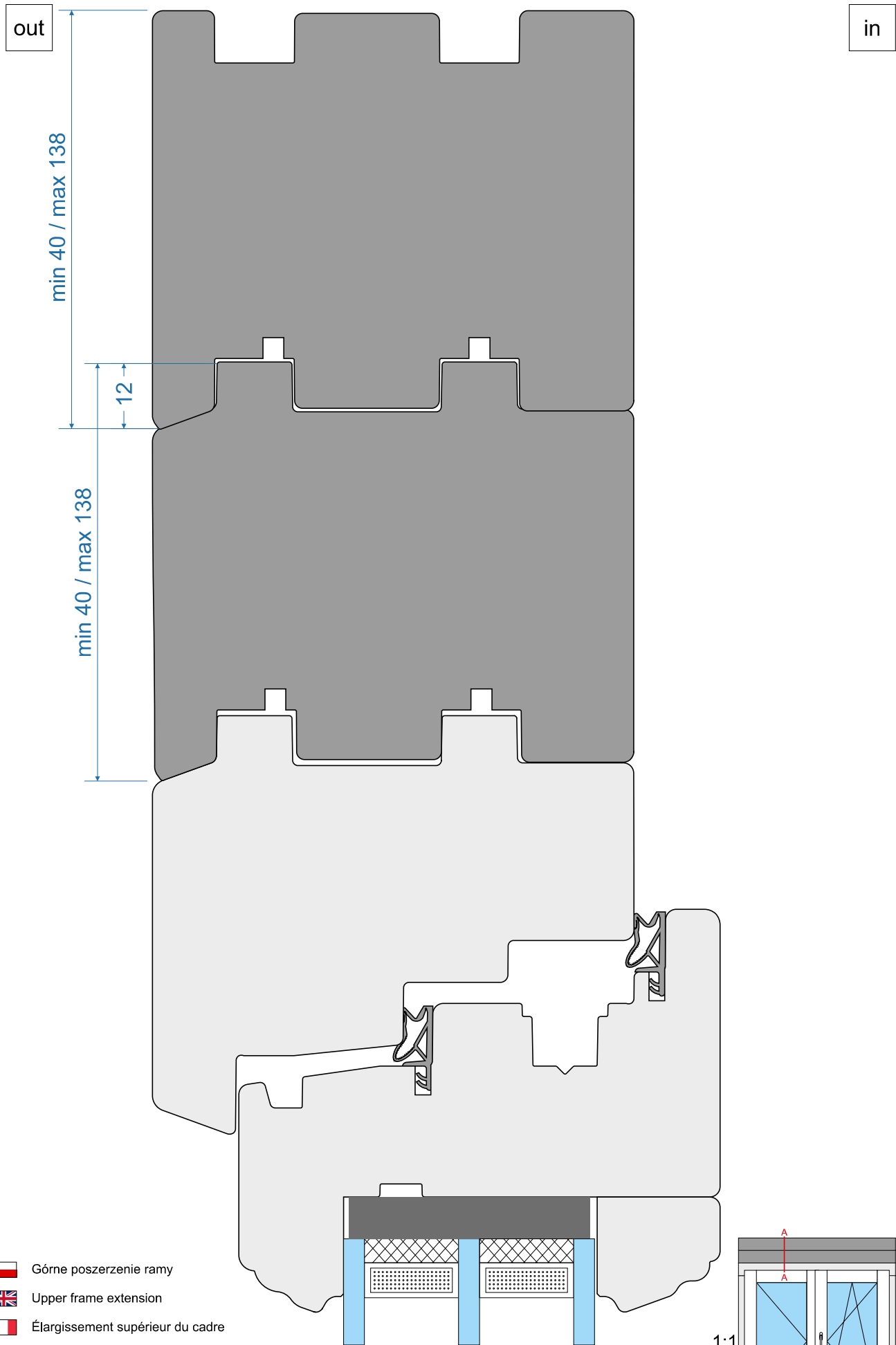
PSV-92-CLS-R-0041





-  Górne poszerzenie ramy
-  Upper frame extension
-  Élargissement supérieur du cadre
-  Estensione del telaio superiore
-  Obere Rahmenverbreitung

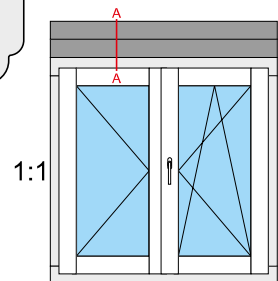

PSV-92-CLS-R-0042

out

in





Passiv 92mm Classic „S”

Passiv 92mm Classic „R”

min 57 / max 138

12

12

-  Środkowe poszerzenie ramy
-  Middle frame extension
-  Montant d'assemblage
-  Montante di accoppiamento
-  Zentral Rahmenverbreiterung

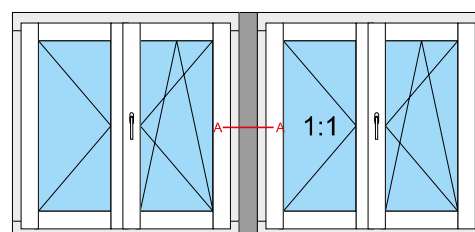



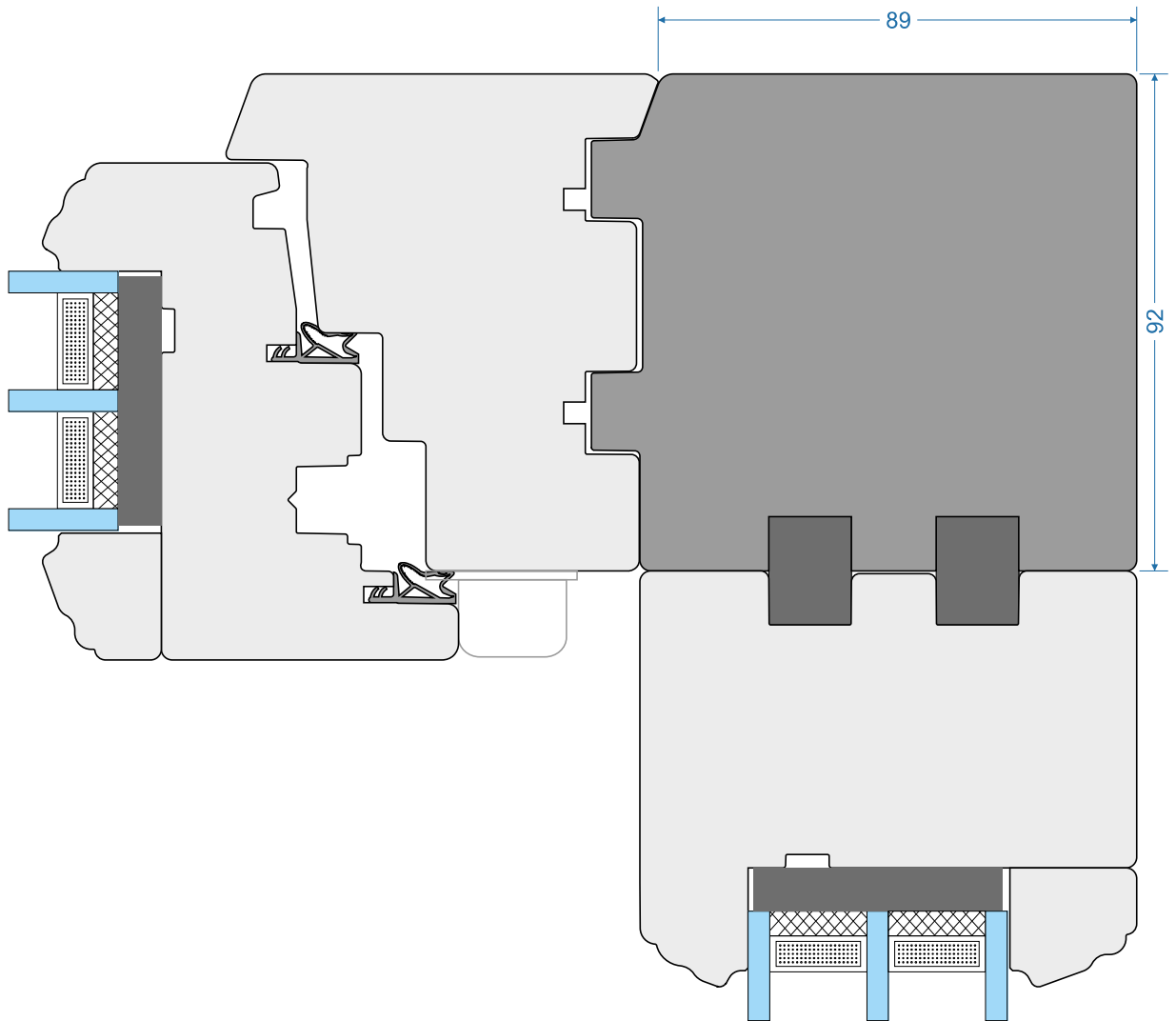

PSV-92-CLS-R-0043

out



in

-  Łącznik 90 stopni
-  90 degree corner connecting post
-  Montant d'assemblage à 90 degrés
-  Montante di accoppiamento 90 gradi
-  90-Grad-Eckpfosten

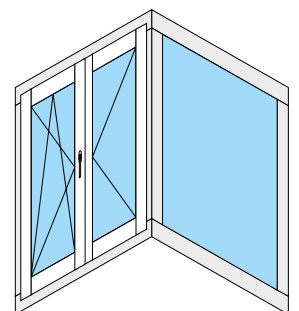

PSV-92-CLS-R-0044

out

in

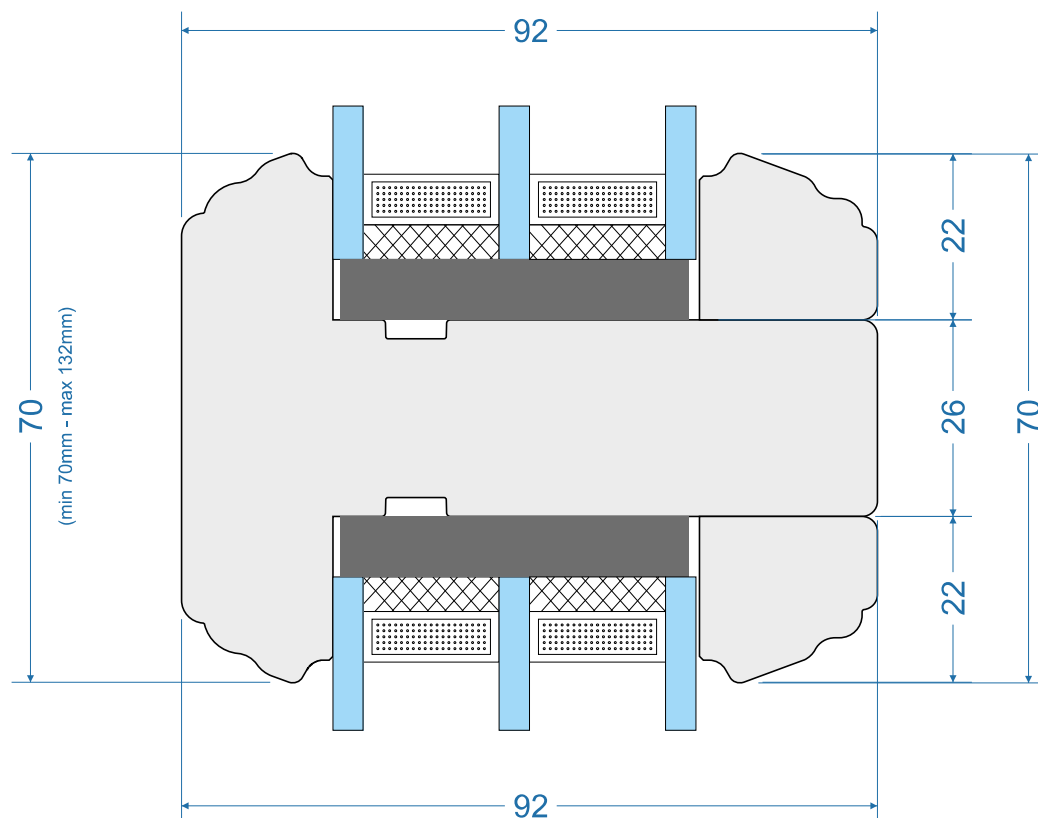

-  Szpros konstrukcyjny
-  Construction type muntin
-  De vrais crossillon
-  Traverso
-  Glasteilende Sprosse

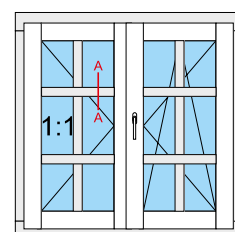

PSV-92-CLS-R-0045

out

in

W-01

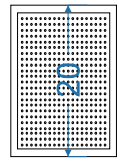
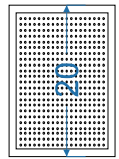
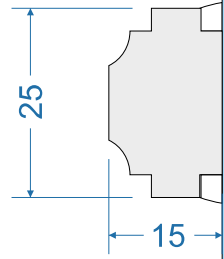

W-02

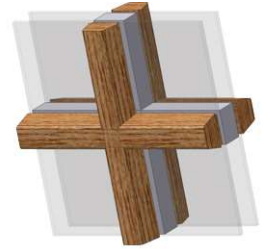
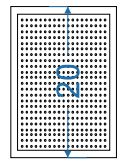
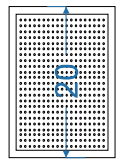
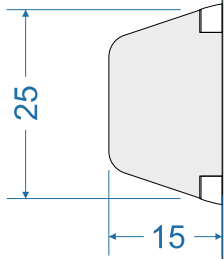

W-03

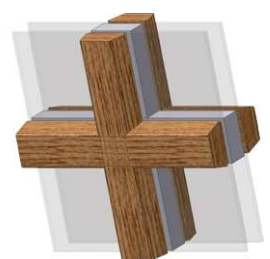
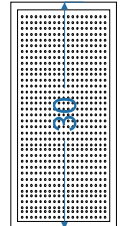
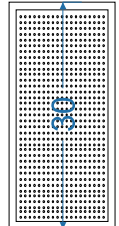
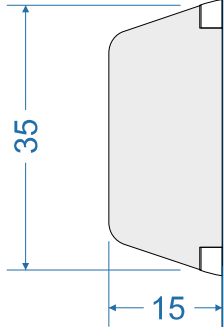



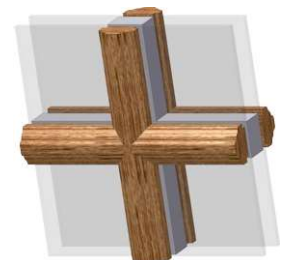
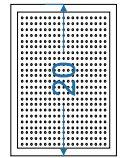
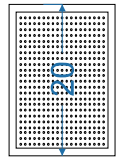
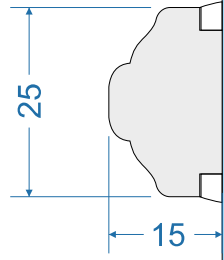

W-04

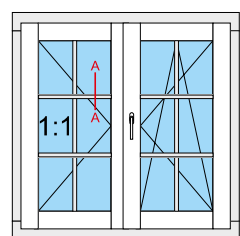
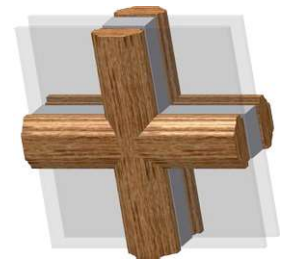
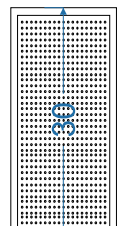
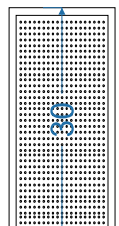
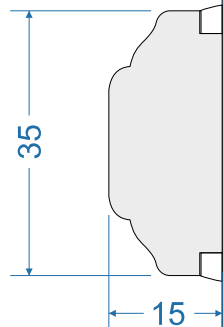

W-05



-  Szpros wideński (Duplex)
-  Vienna muntin (Duplex)
-  Petits bois Viennoise (Duplex)
-  Traverse incollate Viennese (Duplex)
-  Wiener Sprosse (Duplex)

out

in

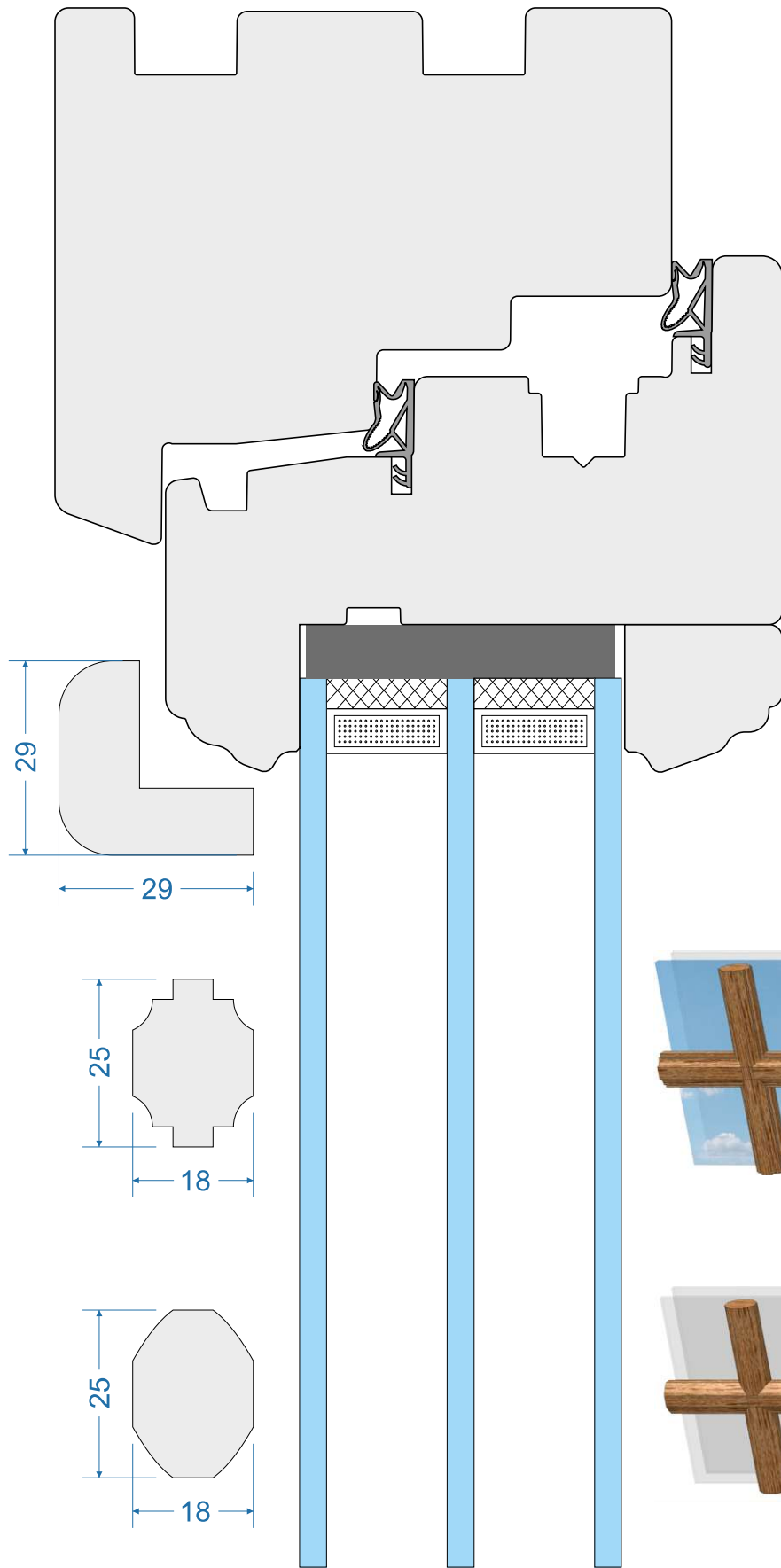

P-01

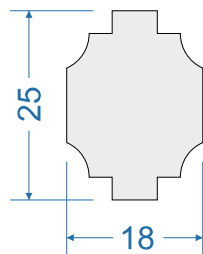

P-02

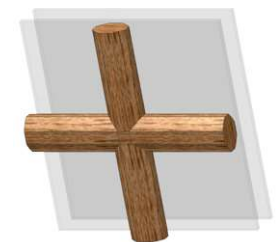
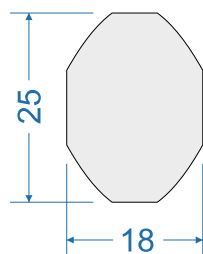

-  Szpros otwierany
-  Openable muntin
-  Croisillon ouvrable
-  Montatura apribile
-  Aufklappbare Sprossen

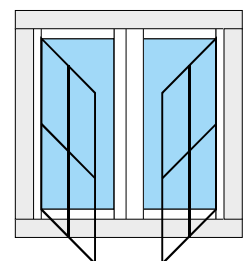

PSV-92-CLS-R-0047