



**VIDAWO**

Windows | Doors | Shutters  
MANUFACTURER

1/2023

# Energio 80mm „R”

*ENR-80-R*



Energio 80mm „S”

Energio 80mm „R”

Energio 80mm Klassik „S”

Energio 80mm Klassik „R”

Passiv 92mm „S”

Passiv 92mm „R”

ENR-80-R-001

out

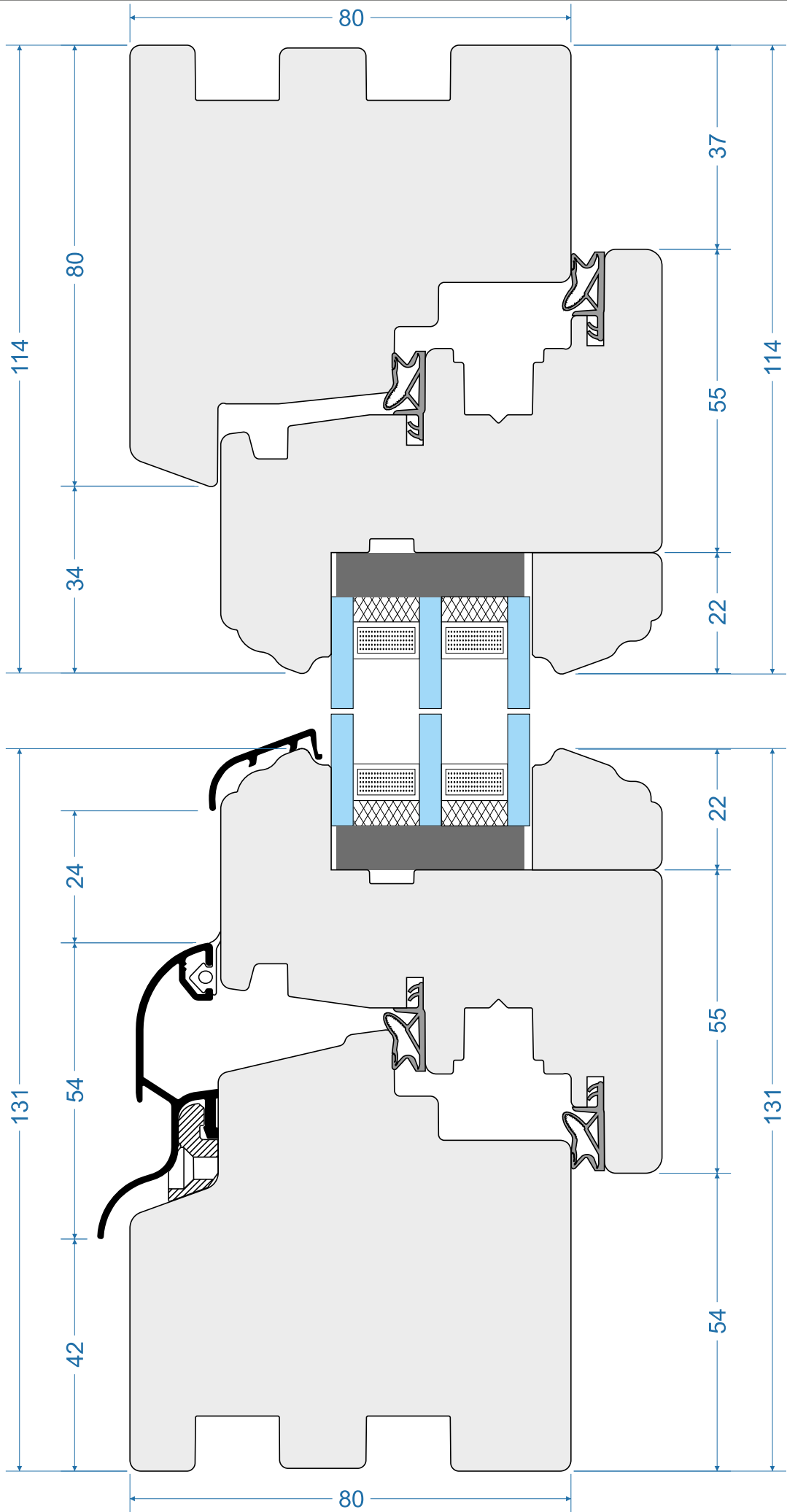

in

ENR-80-R-002

out

in

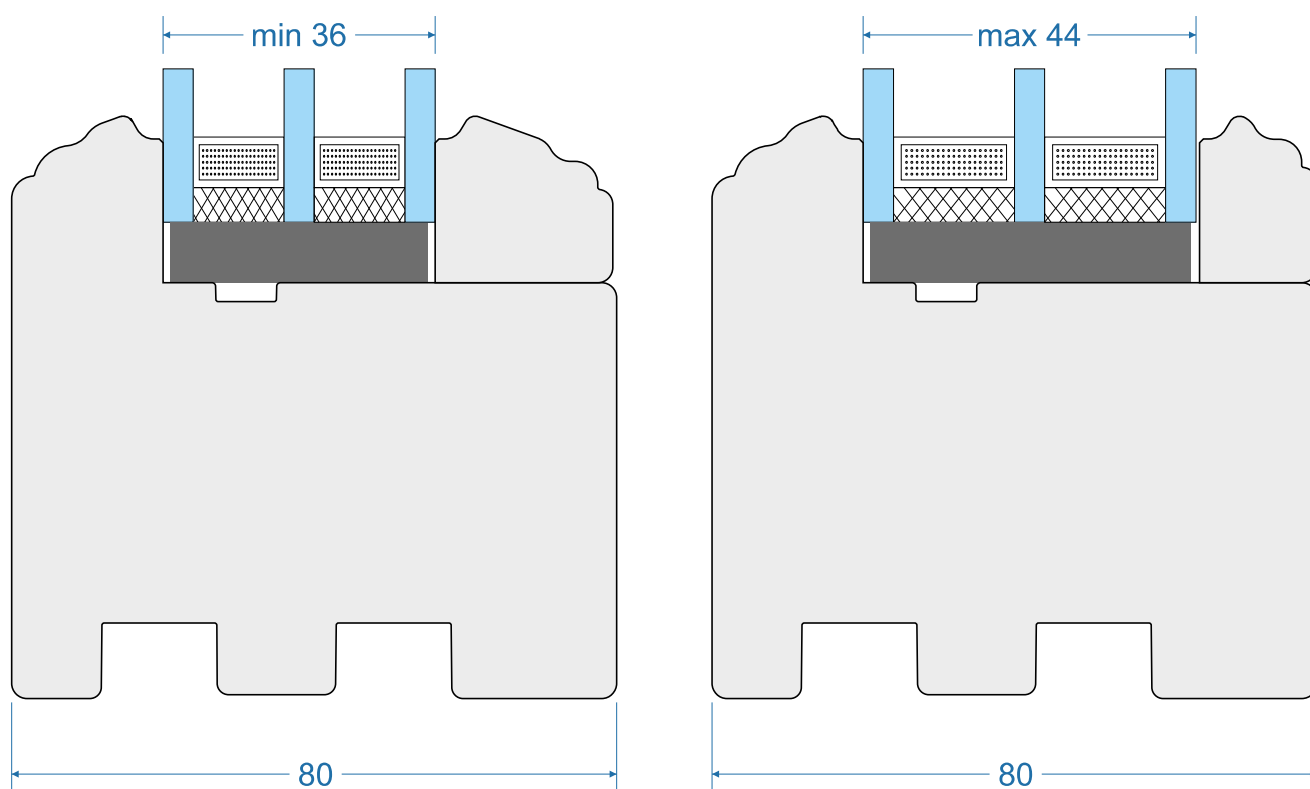

 Minimalna / maksymalna grubość pakietu szybowego

 Minimum / maximum glass thickness

 Épaisseur minimale / maximale du verre

 Spessore minimo/massimo del vetro

 Minimale / maximale Stärke des verglasungs paketes

out

in

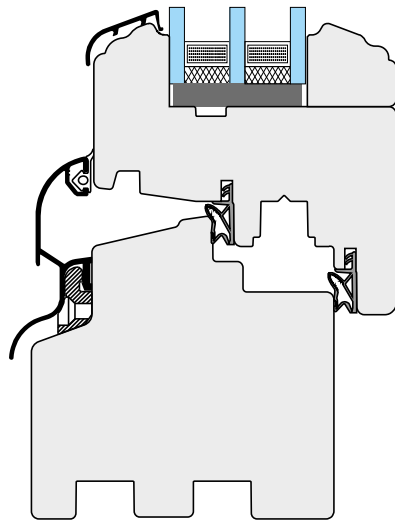

80 DN

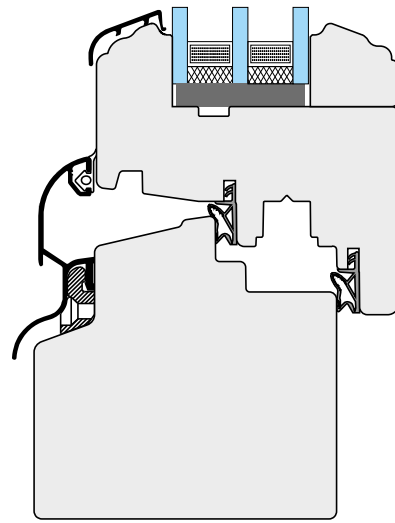

R3

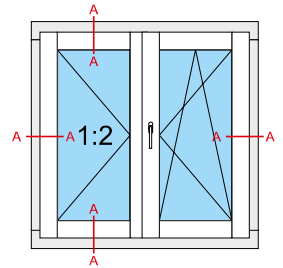

- Stabdardowe frezowanie ramy
- Standard frame finish
- Finition de cadre standard
- Finitura telaio standard
- Standard-Rahmenausführung

out

in

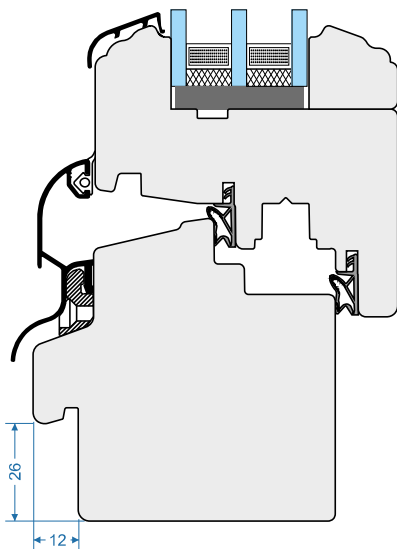

EXT 12x26

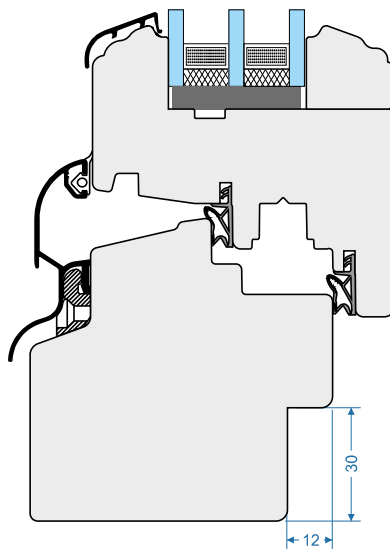

INT 12x30

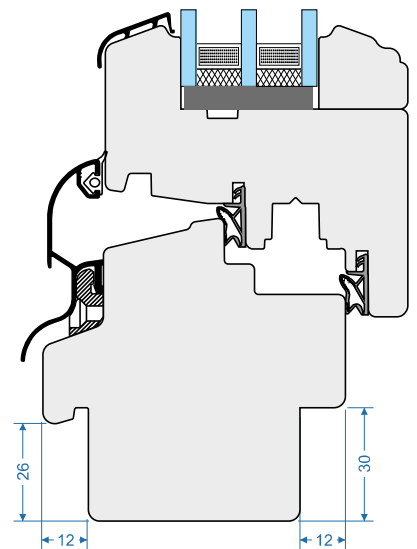

EXT 12x26  
INT 12x30



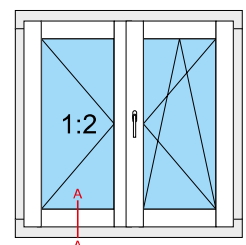

- Frezy pod parapety
- Groove for the window sill
- Rainure pour le rebord de la fenêtre
- Scanalatura per il davanzale della finestra
- Nut für die Fensterbank

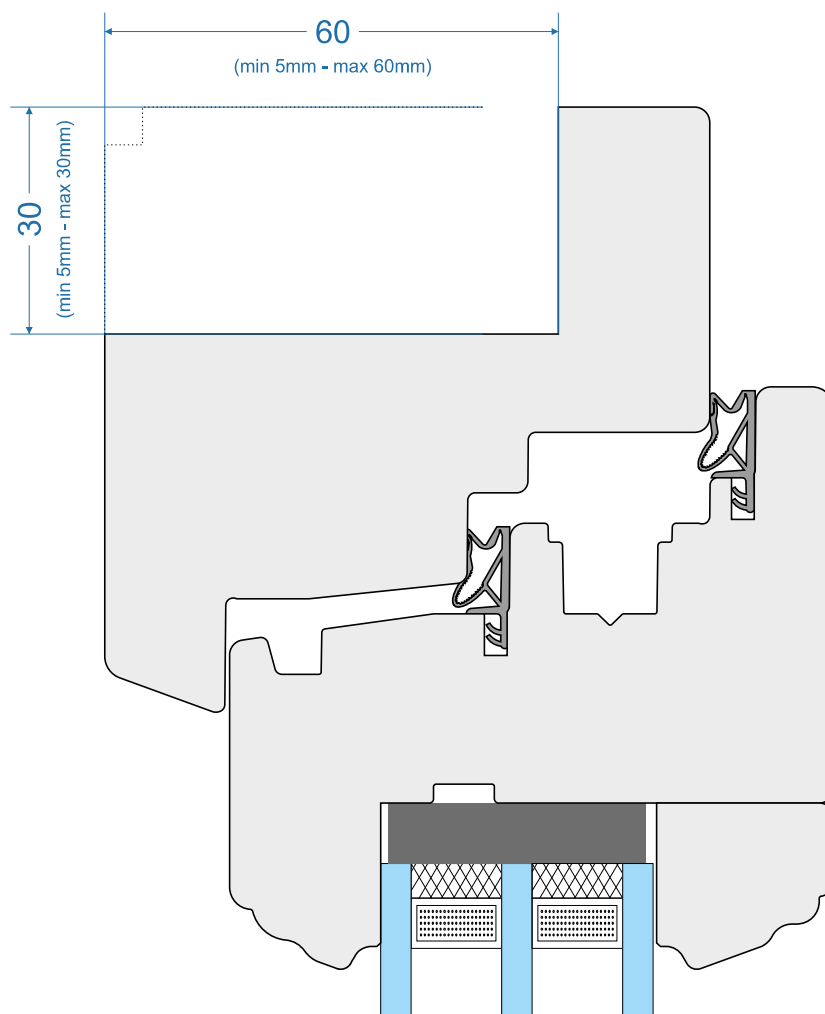

out

in



-  Frez renowacyjny od zewnątrz
-  Renovation groove from the outside
-  Rainure de rénovation à l'extérieur
-  Scanalatura di ristrutturazione all'esterno
-  Renovierungsnut außen

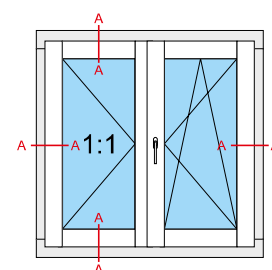

ENR-80-R-005

Energio 80mm „S”

Energio 80mm „R”

Energio 80mm Classik „S”

Energio 80mm Classik „R”





Passiv 92mm „S”

Passiv 92mm „R”

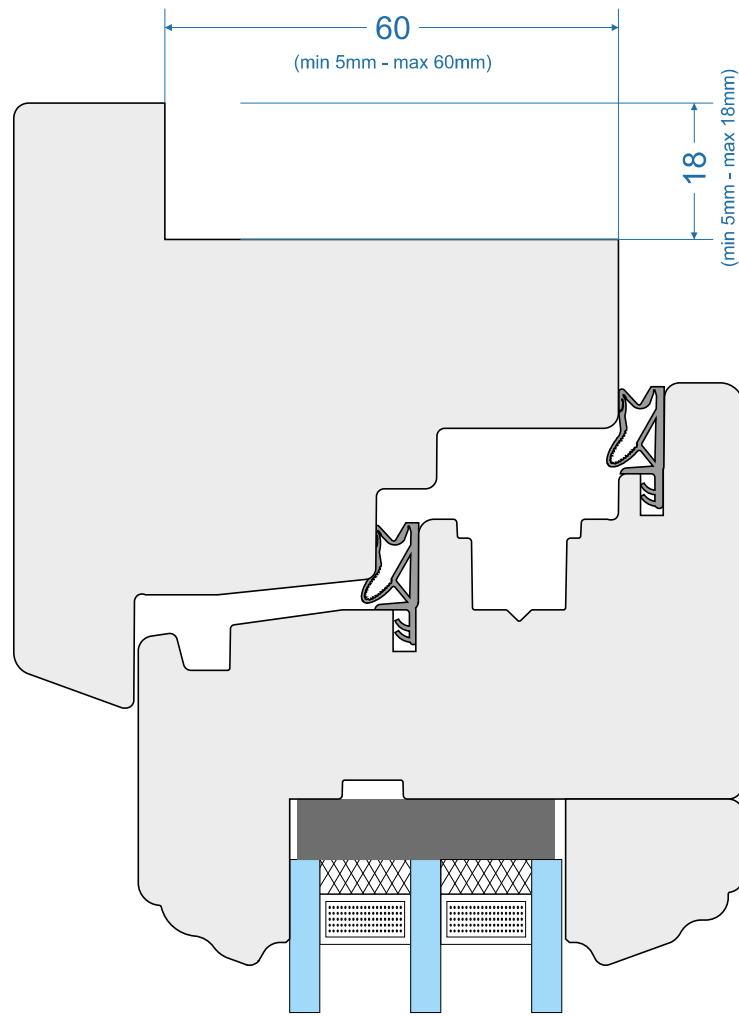
out





in

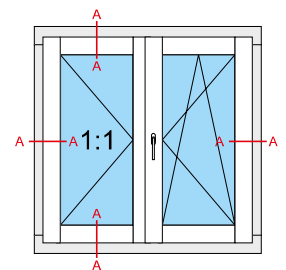

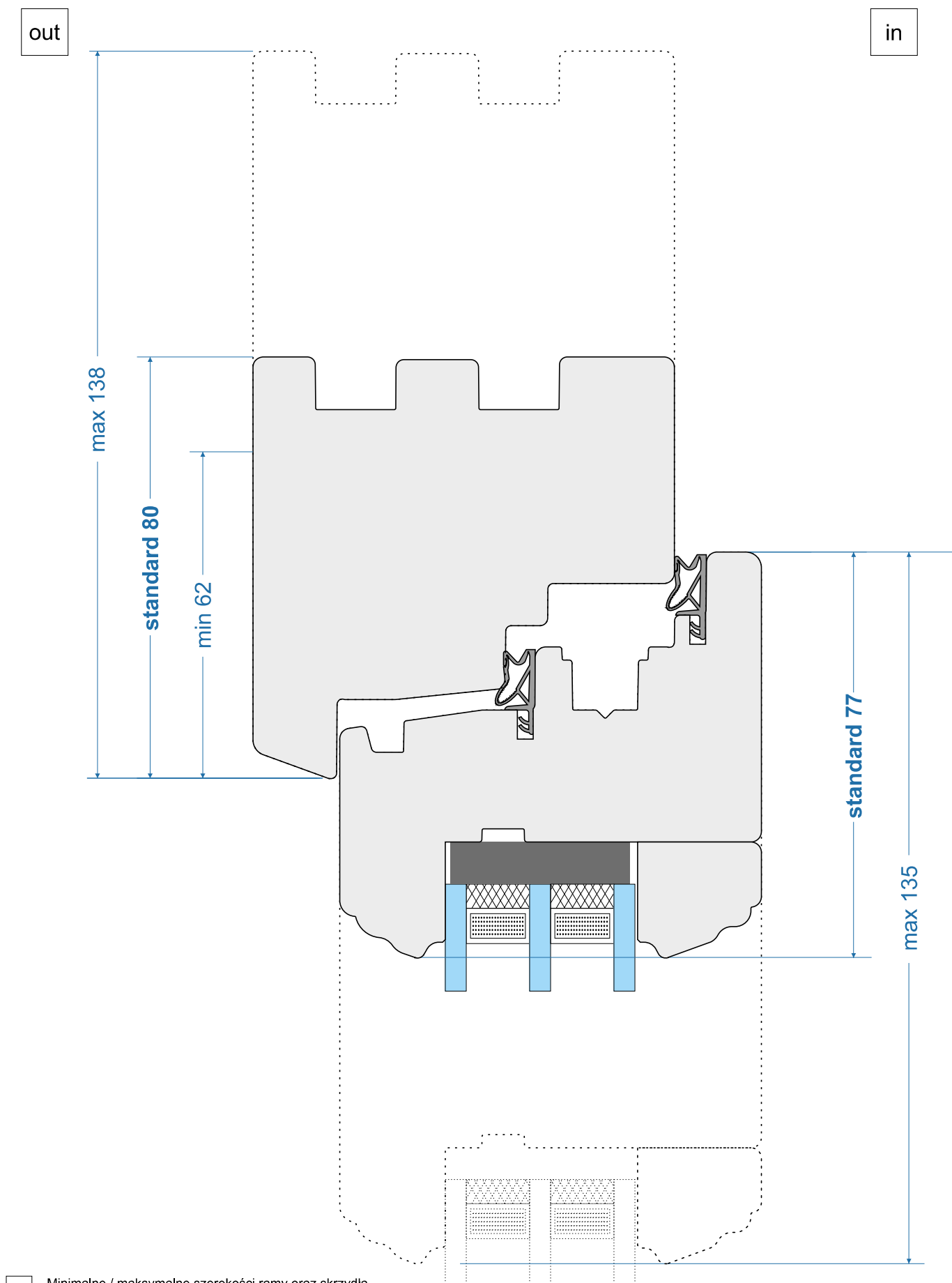
-  Frez renowacyjny od wewnątrz
-  Renovation groove from the inside
-  Rainure de rénovation à l'intérieur
-  Scanalatura di ristrutturazione all'interno
-  Renovierungsnut auf der Innenseite





-  Minimalne / maksymalne szerokości ramy oraz skrzydła
-  Minimum / maximum dimensions of the frame and sash
-  Dimensions minimales / maximales du cadre et du châssis
-  Dimensioni minime/massime del telaio e dell'anta
-  Minimale / maximale breite des rahmen und des flügels

ENR-80-R-007

Energio 80mm „S”

Energio 80mm „R”

Energio 80mm Classik „S”

Energio 80mm Classik „R”

Passiv 92mm „S”

Passiv 92mm „R”

out

in

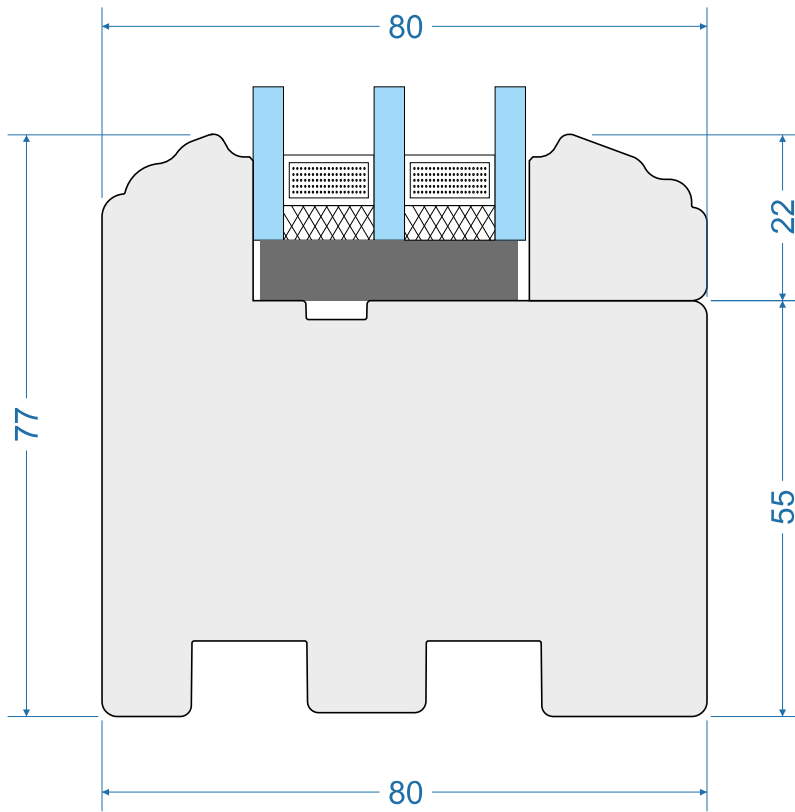

-  Fix w ramie
-  Fixed window
-  Chassis fixe
-  Finestra fissa
-  Fenster fest im rahmen

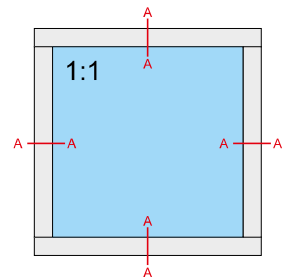

ENR-80-R-008



out

in

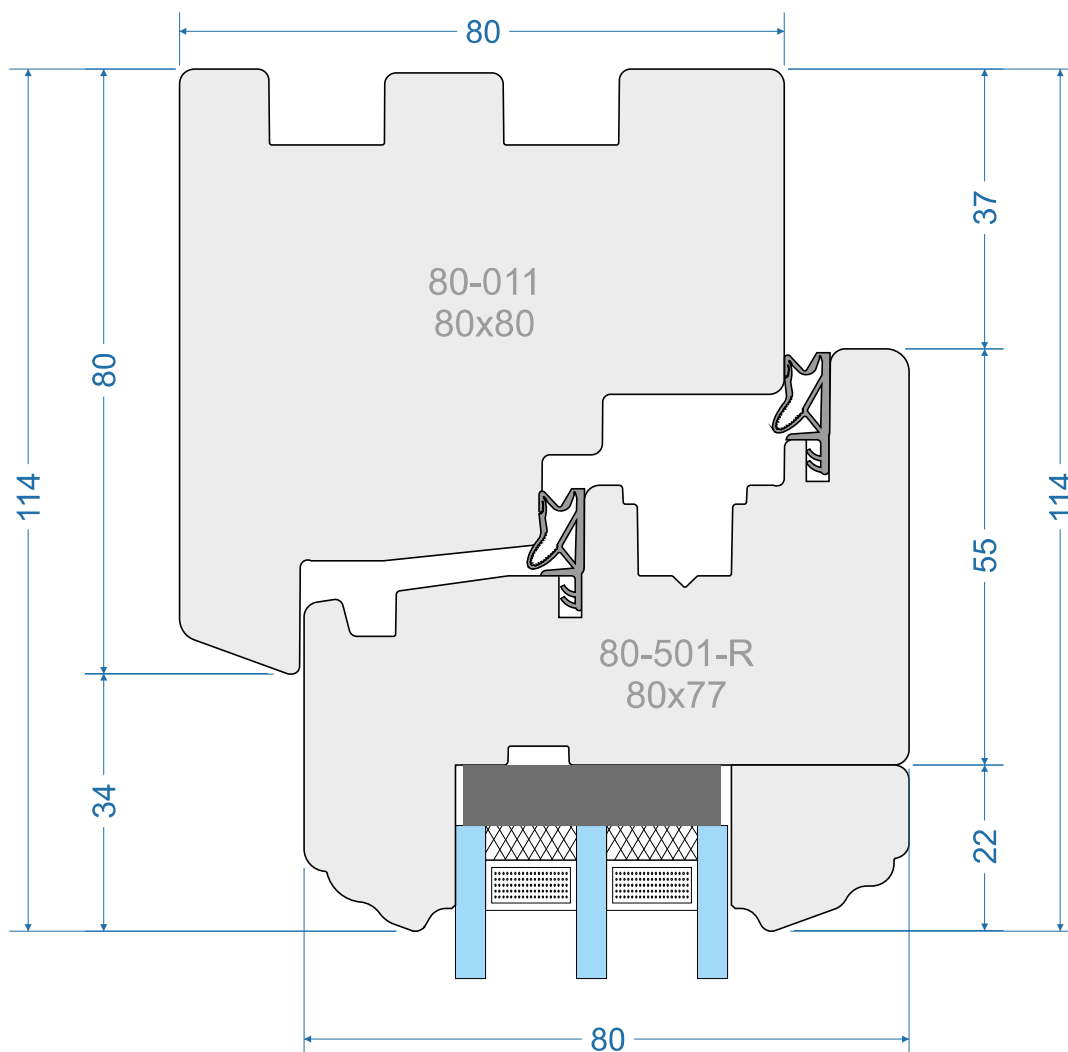

-  Rama + skrzydło
-  Frame + sash
-  Cadre + ouvrant
-  Telaio + anta
-  Rahmen + Flügel

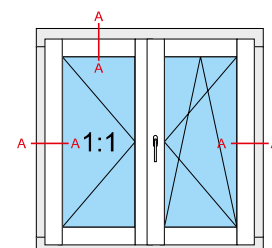

ENR-80-R-009

Energio 80mm „S”

Energio 80mm „R”

Energio 80mm Classik „S”

Energio 80mm Classik „R”

Passiv 92mm „S”

Passiv 92mm „R”

out

in

Energio 80mm „S”

Energio 80mm „R”

Energio 80mm Classik „S”

Energio 80mm Classik „R”

Passiv 92mm „S”

Passiv 92mm „R”

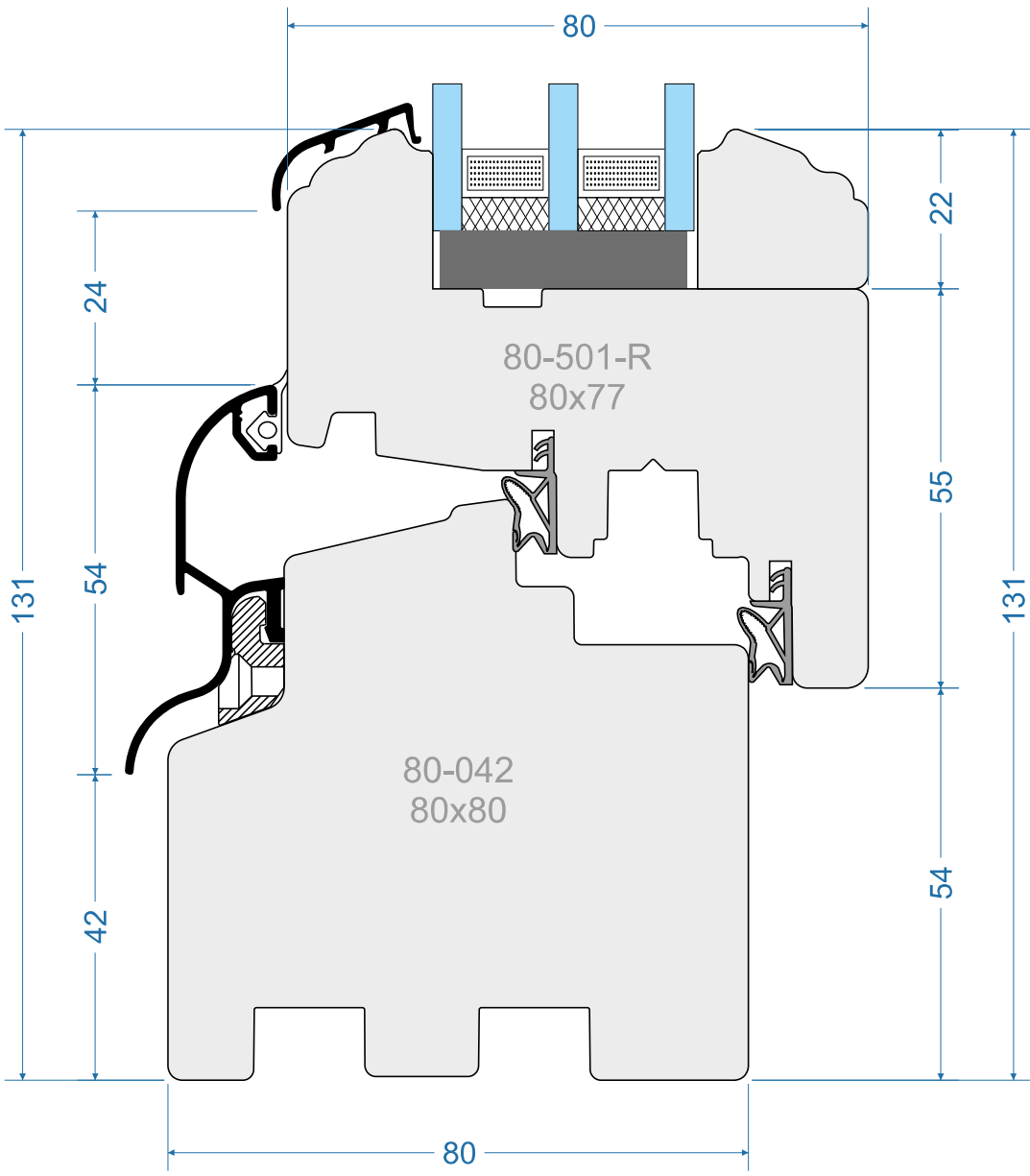

-  Rama + skrzydło
-  Frame + sash
-  Cadre + ouvrant
-  Telaio + anta
-  Rahmen + Flügel

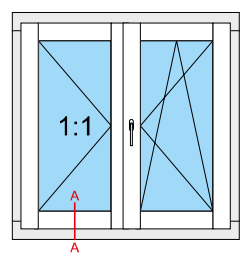

out

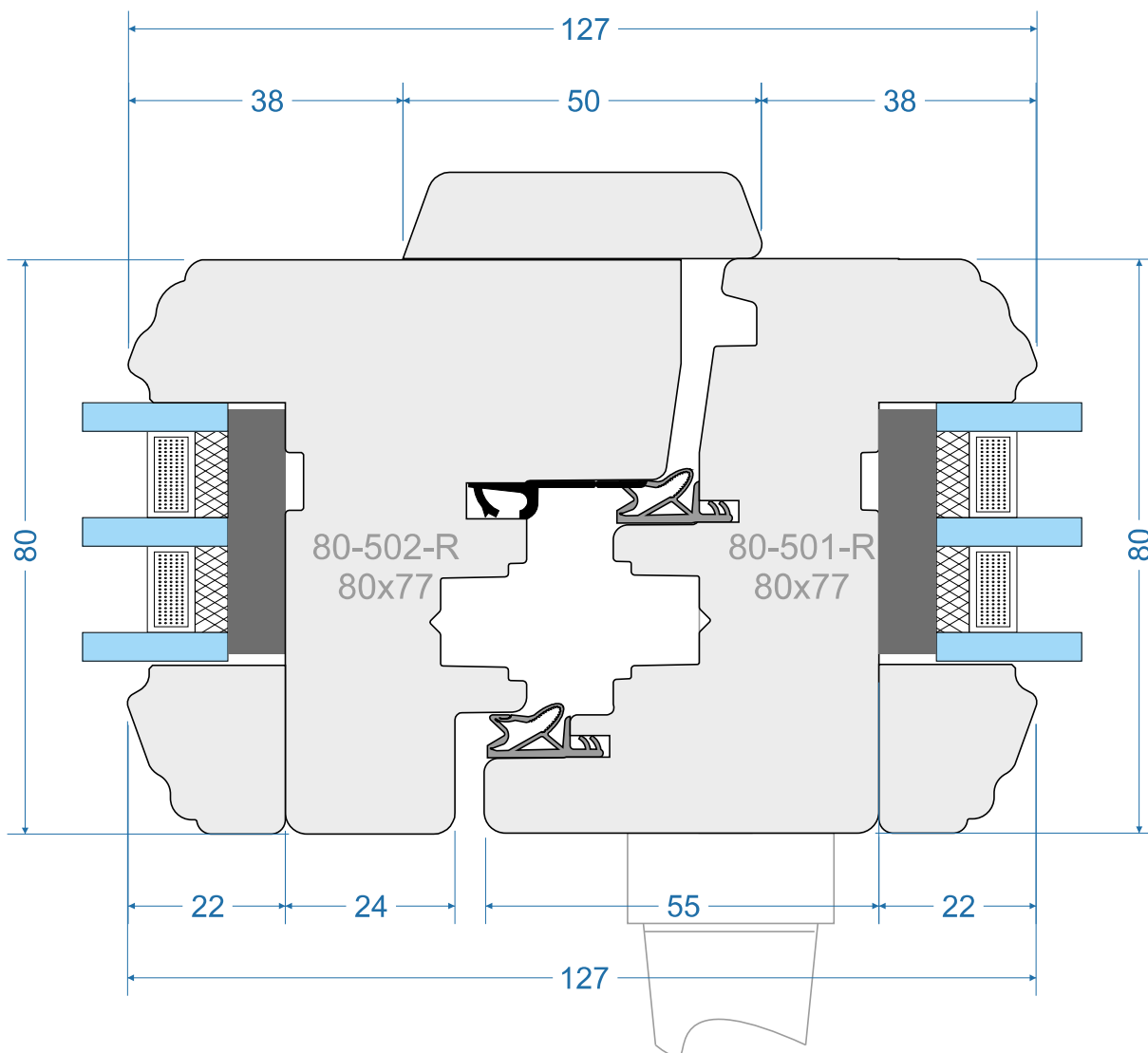

in

-  Stupek ruchomy
-  Moveable post
-  Meneau mobile
-  Montante mobile
-  Stulp

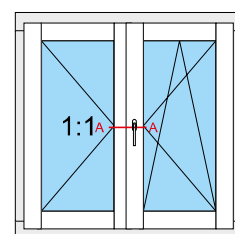

ENR-80-R-0011

Energio 80mm „S”

Energio 80mm „R”

Energio 80mm Classik „S”

Energio 80mm Classik „R”



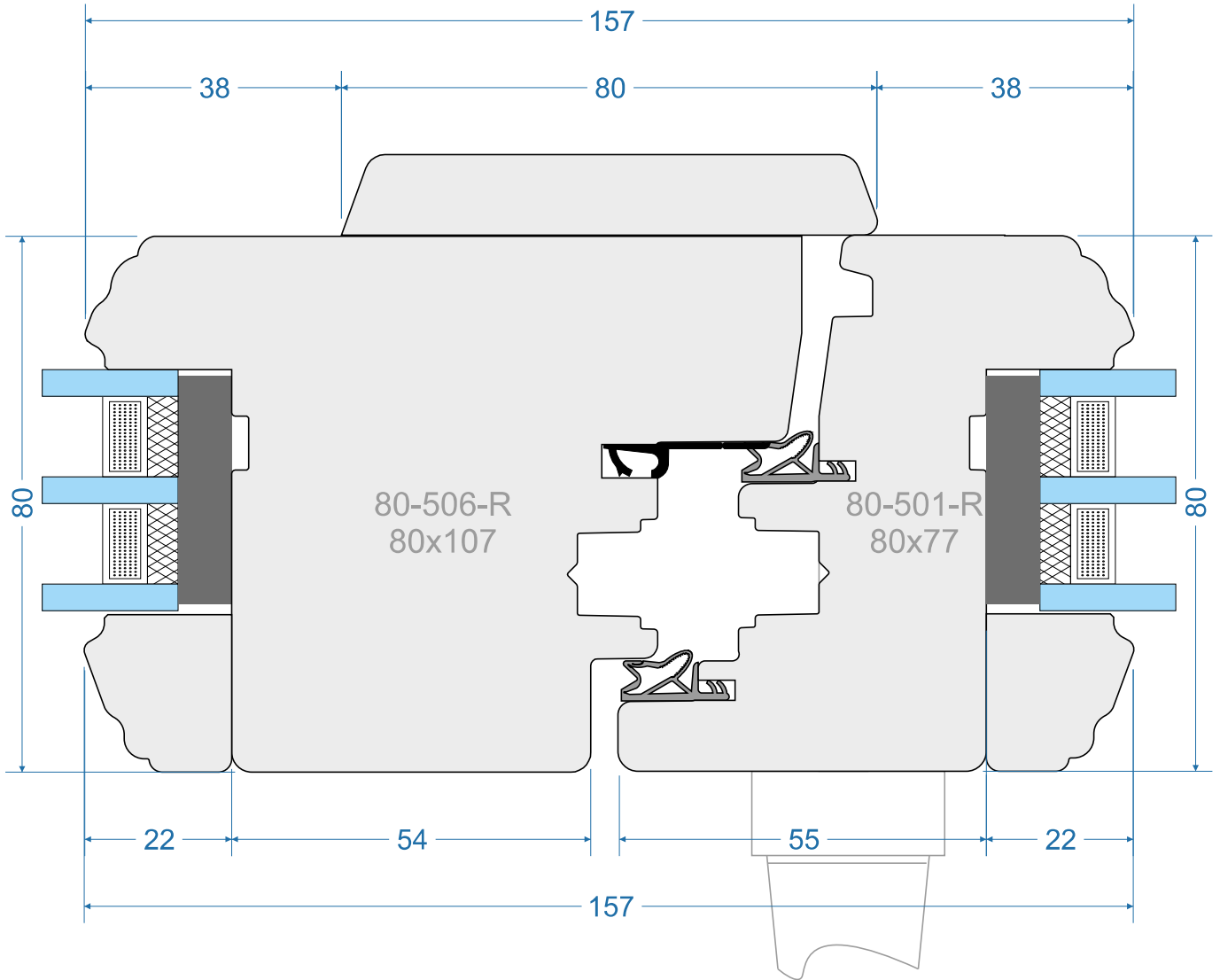

Passiv 92mm „S”

Passiv 92mm „R”

out



in



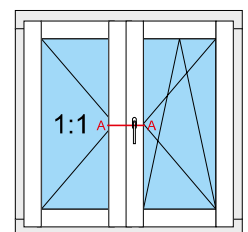

-  Stupek ruchomy - równe elementy
-  Movable post - equal elements
-  Meneau mobile - éléments égaux
-  Montante mobile - elementi simmetrici
-  Stulp - gleiche Elemente

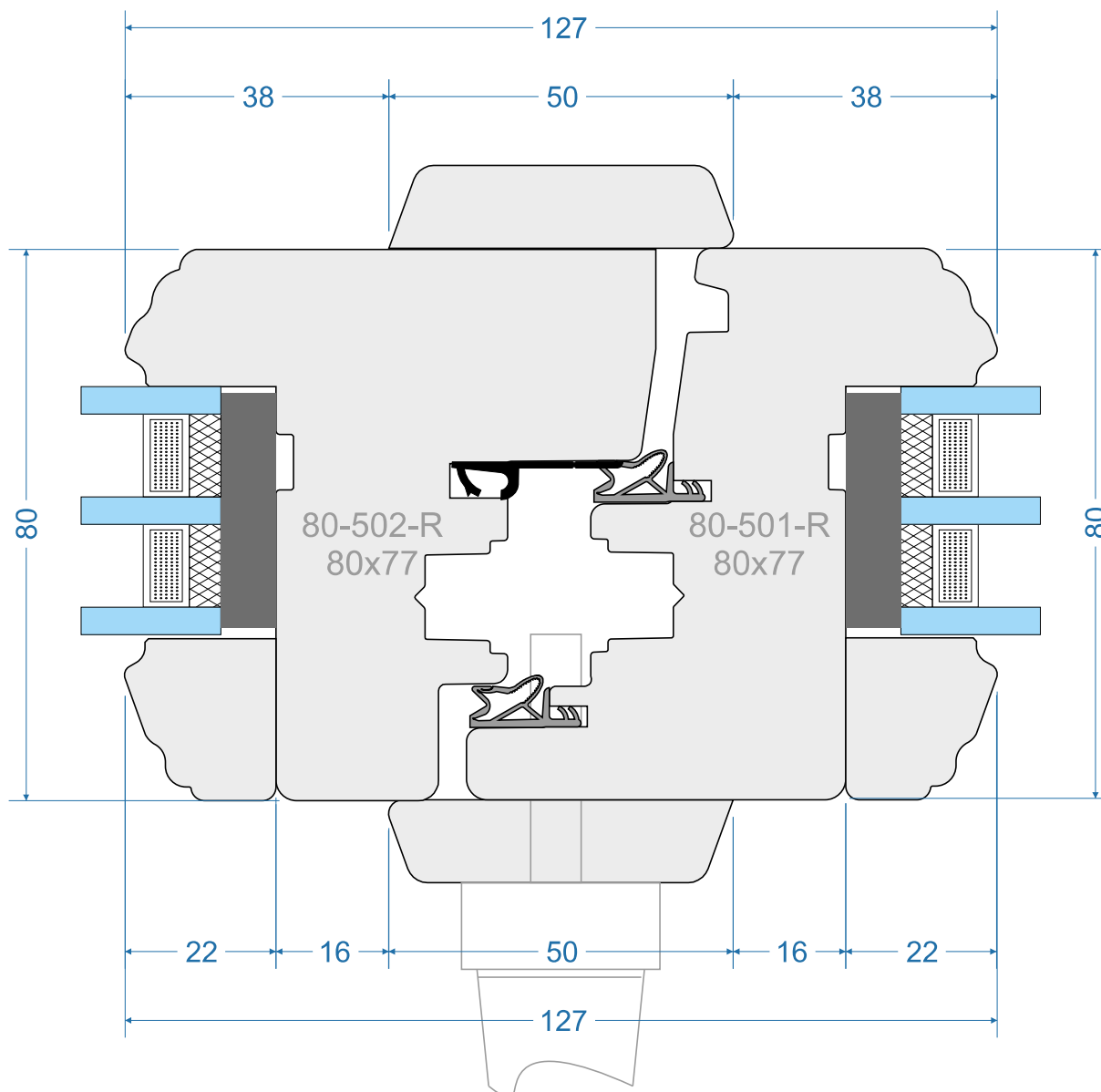

out



in

-  Stupek ruchomy - klamka centralna
-  Moveable post - central handle
-  Meneau mobile - poignée centrale
-  Montante mobile - maniglia centrale (entrata zero)
-  Stulp - zentraler Griff

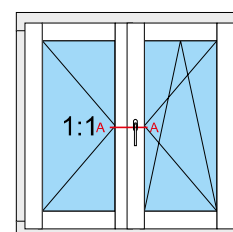

ENR-80-R-0013

Energio 80mm „S”

Energio 80mm „R”

Energio 80mm Classik „S”

Energio 80mm Classik „R”



Passiv 92mm „S”

Passiv 92mm „R”

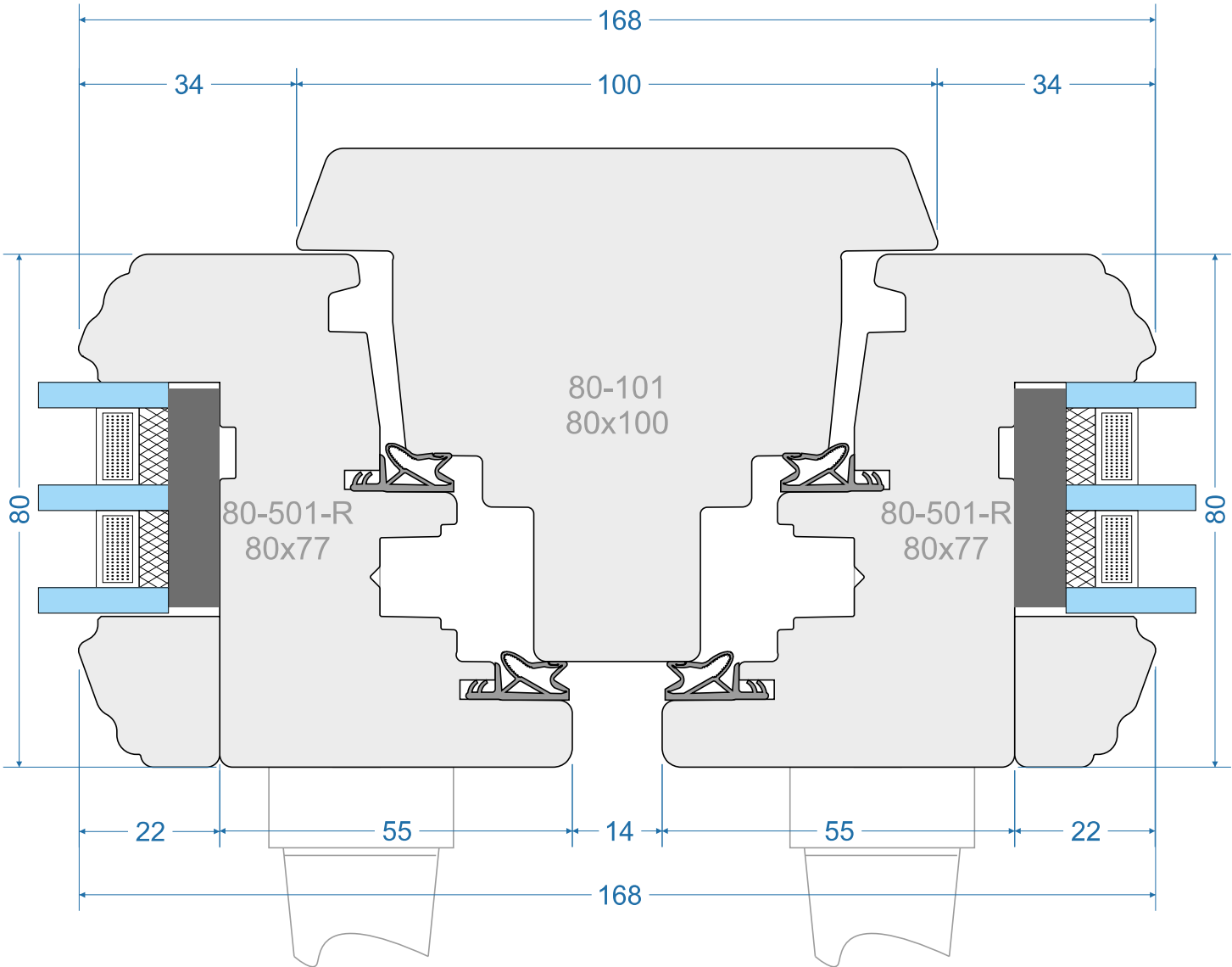
out



in



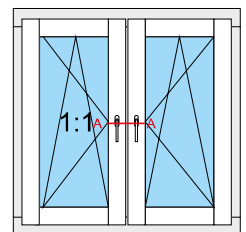

-  Slupek staly 100mm
-  Fixed post 100mm
-  Meneau fixe 100mm
-  Montante verticale fisso 100mm
-  Festen pfosten 100mm

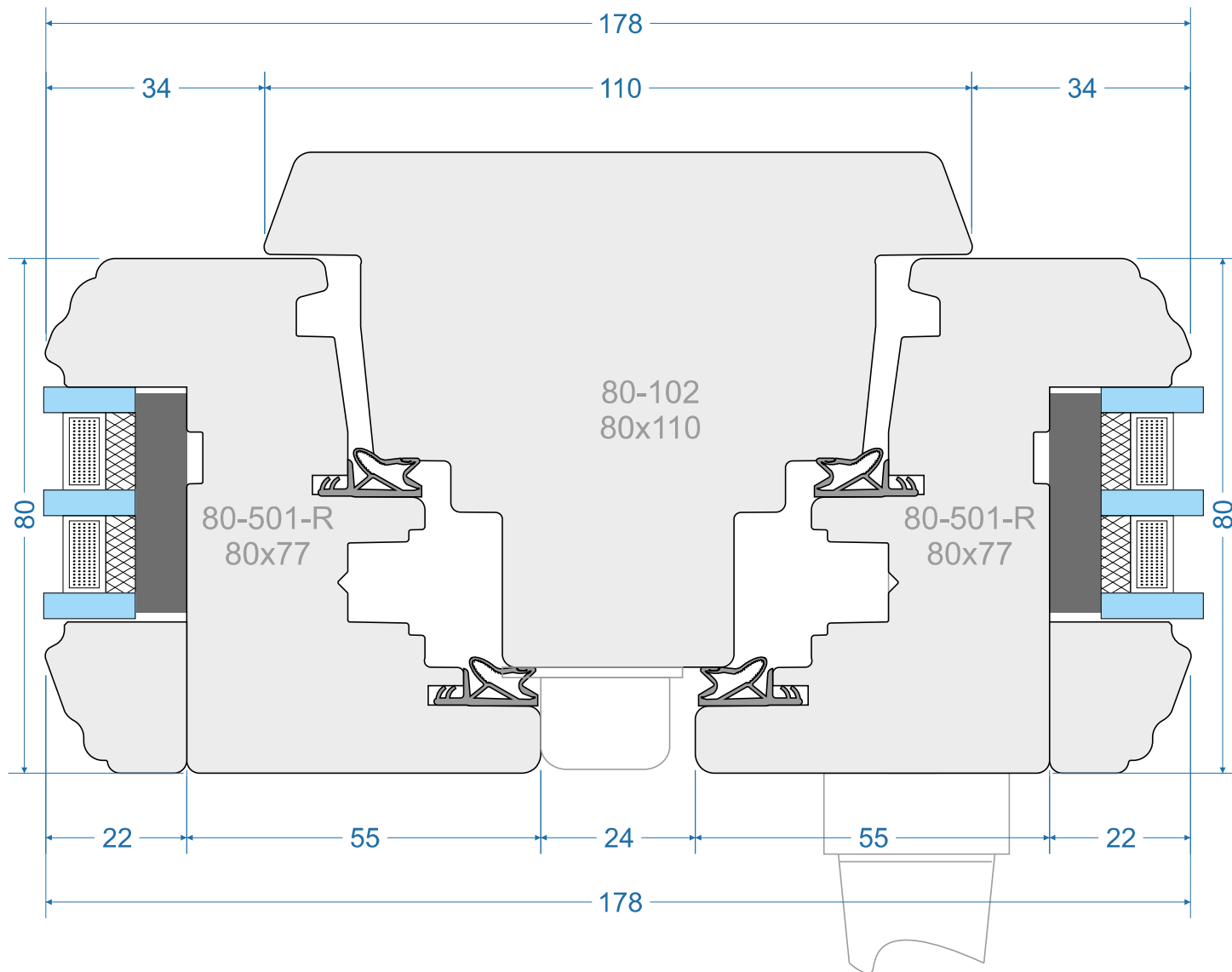

out



in

-  Słupek stalowy 110mm
-  Fixed post 110mm
-  Meneau fixe 110mm
-  Montante verticale fisso 110mm
-  Festen pfosten 110mm

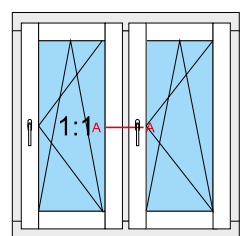

ENR-80-R-0015

Energio 80mm „S”

Energio 80mm „R”

Energio 80mm Klassik „S”





Energio 80mm Klassik „R”

Passiv 92mm „S”

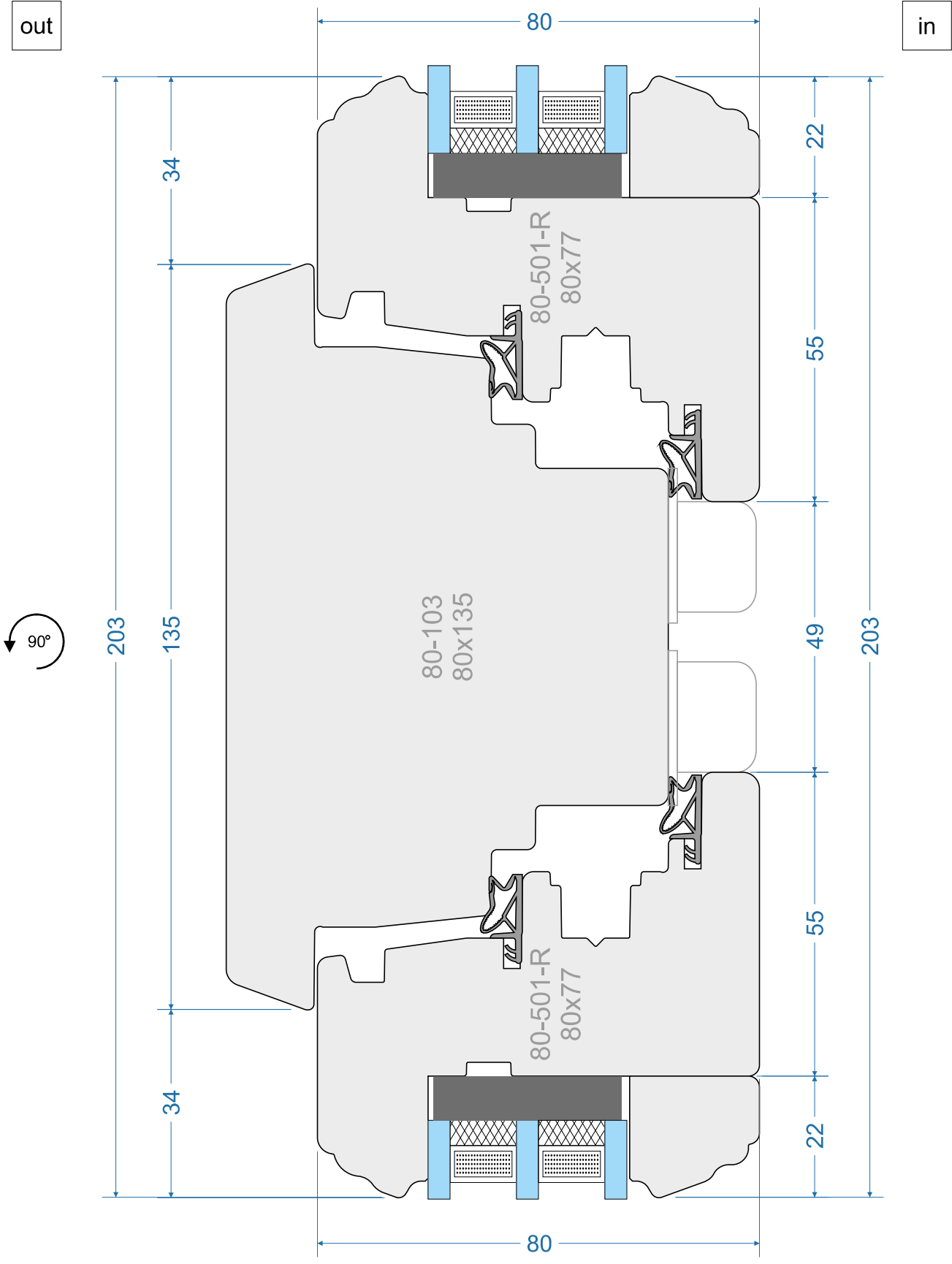
Passiv 92mm „R”

- Passiv 92mm „R”
- Energio 80mm „R”
- Energio 80mm Classik „S”
- Energio 80mm „S”
- Passiv 92mm „S”
- Energio 80mm Classik „R”
- Energio 80mm „R”



-  Slupek staly 135mm
-  Fixed post 135mm
-  Meneau fixe 135mm
-  Montante orizzontale fisso 135mm
-  Festen pfosten 135mm

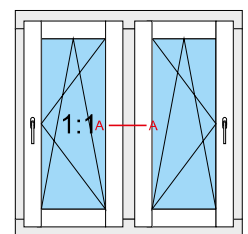





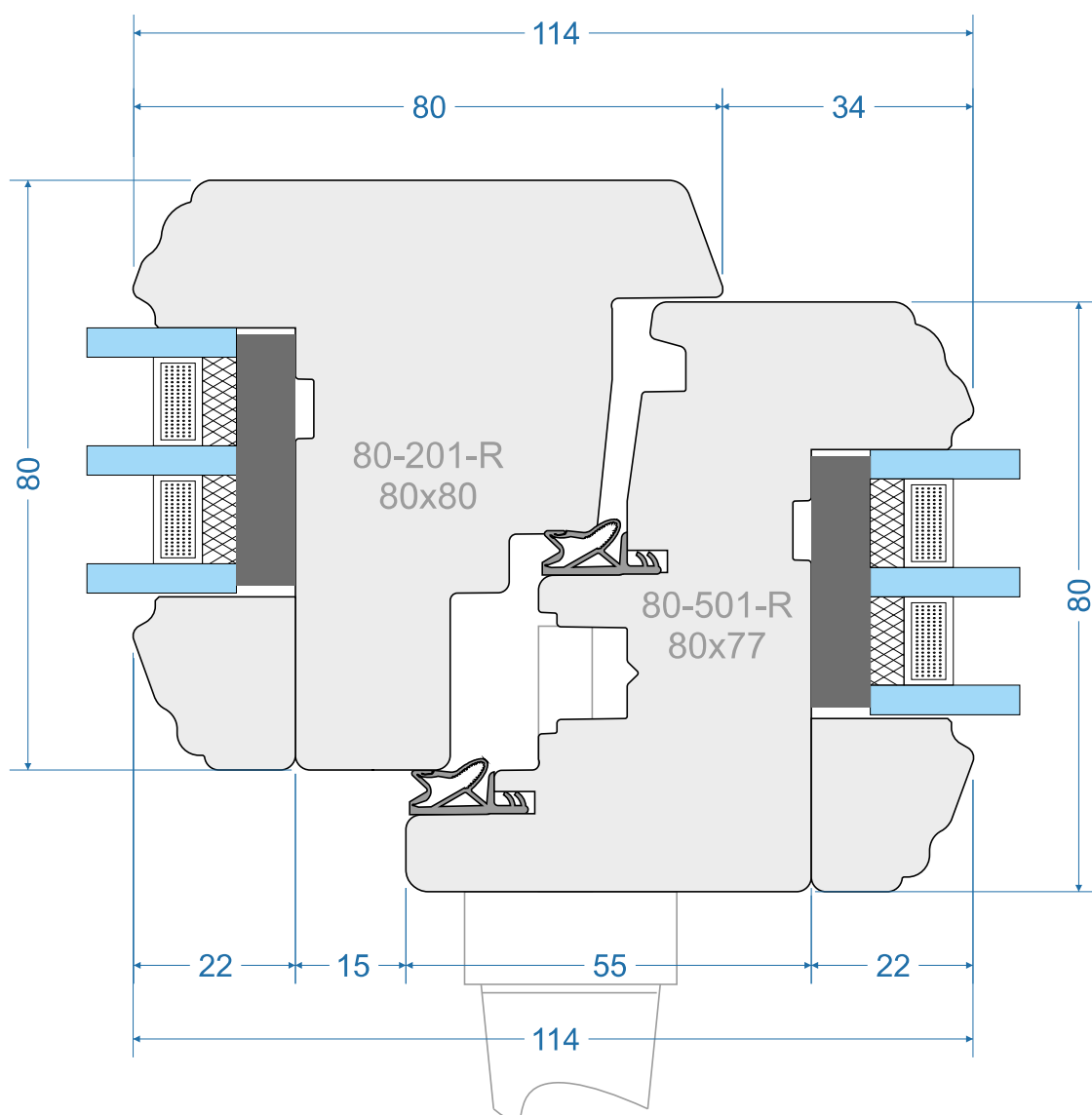

out



in

-  Słupek - skrzydło + fix
-  Post - sash + fix
-  Meneau - ouvrant + fixe
-  Accoppiamento telaio fisso - anta mobile
-  Pfosten - Flügel + Fix

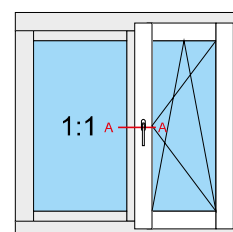

ENR-80-R-0017

Energio 80mm „S”

Energio 80mm „R”

Energio 80mm Classik „S”

Energio 80mm Classik „R”

Passiv 92mm „S”



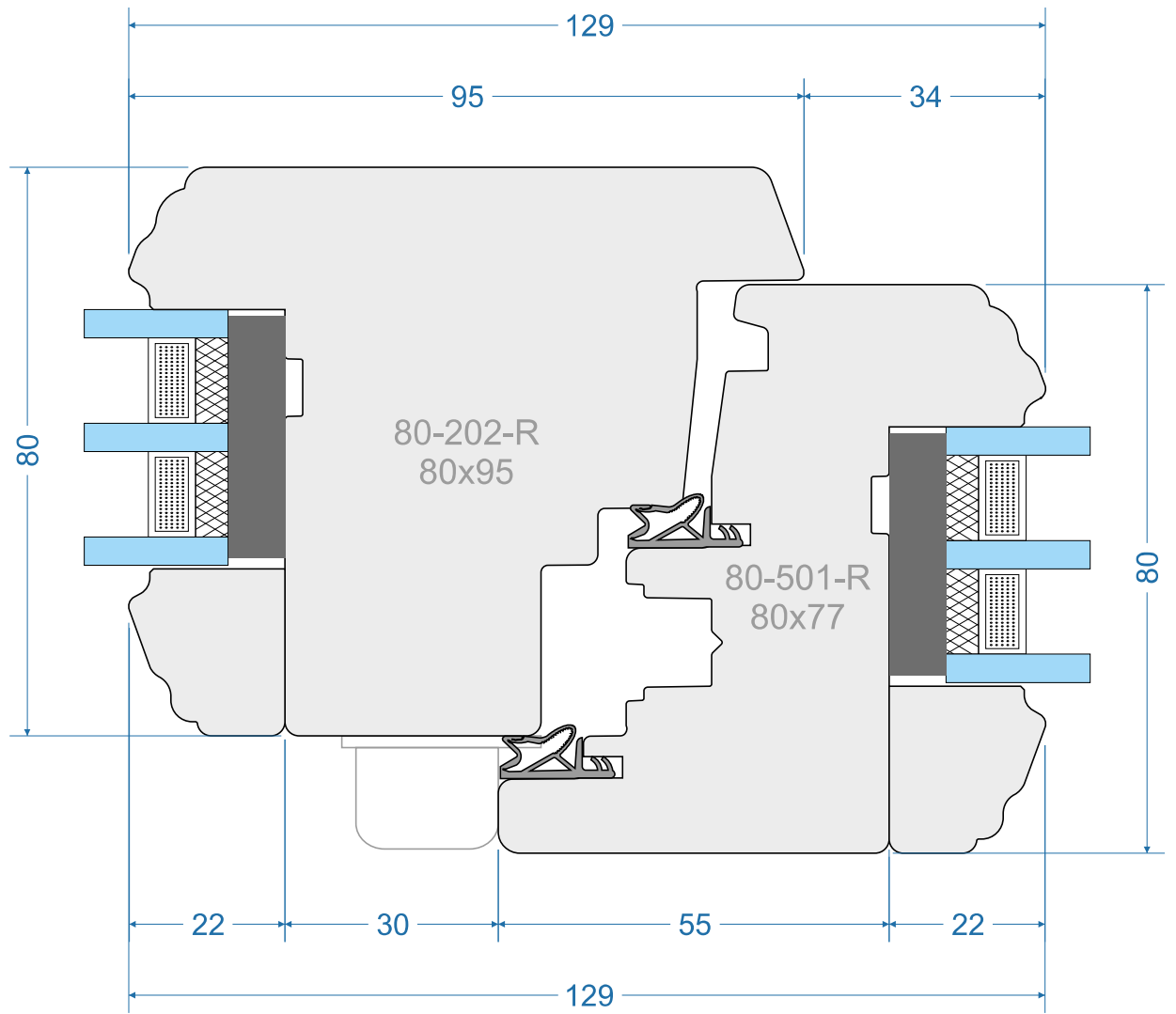

Passiv 92mm „R”

out

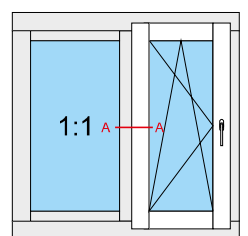

in



-  Słupek - skrzydło + fix
-  Post - sash + fix
-  Meneau - ouvrant+ fixe
-  Accoppiamento telaio fisso - anta mobile
-  Pfosten - Flügel + Fix

Passiv 92mm „R”  
 Passiv 92mm „S”  
 Energo 80mm „R”  
 Energo 80mm „S”  
 Energo 80mm „R”  
 Energo 80mm „S”

out

in

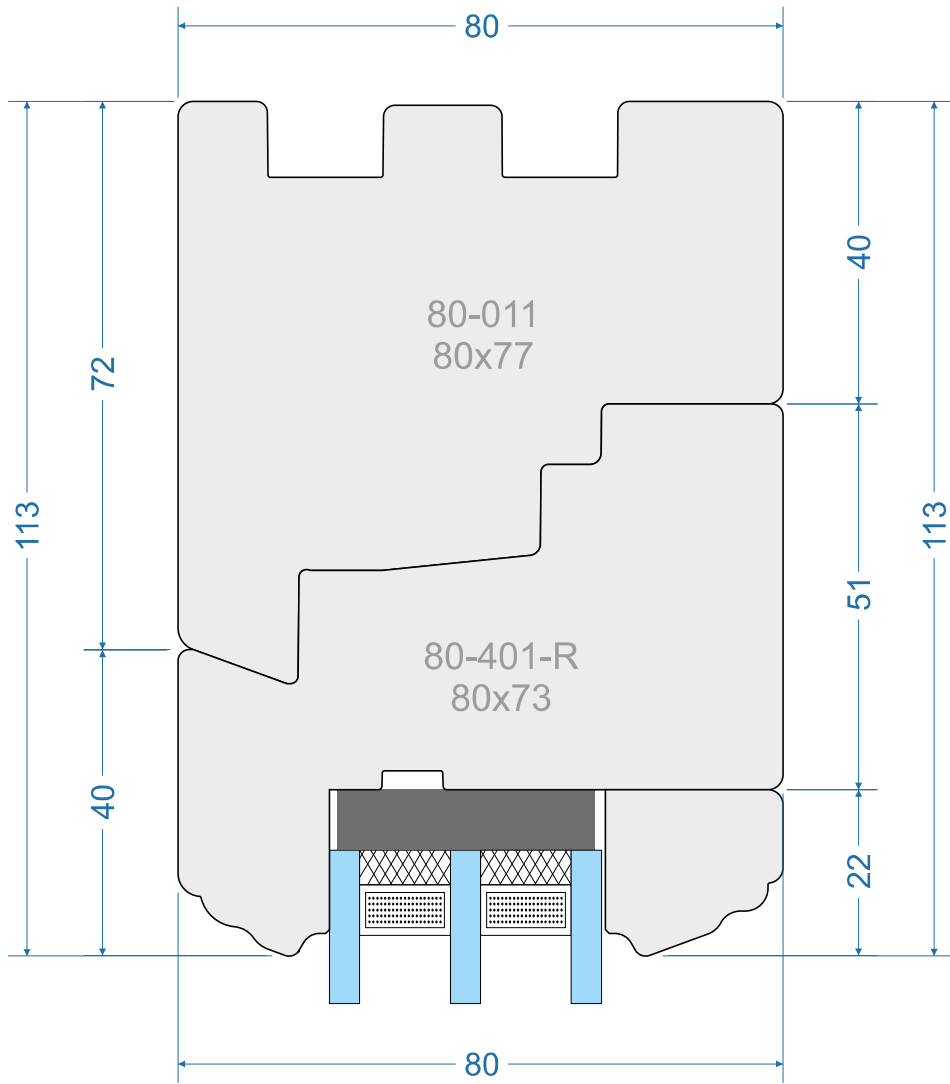

-  Wyrównanie górne
-  Top alignment
-  Alignement supérieur
-  Allineamento superiore
-  Ausrichtung nach oben

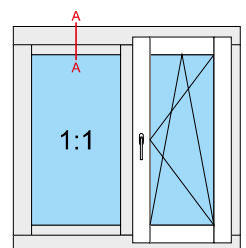

ENR-80-R-0019

Energio 80mm „S”

Energio 80mm „R”

Energio 80mm Classic „S”

Energio 80mm Classic „R”

Passiv 92mm „S”

Passiv 92mm „R”

out

in

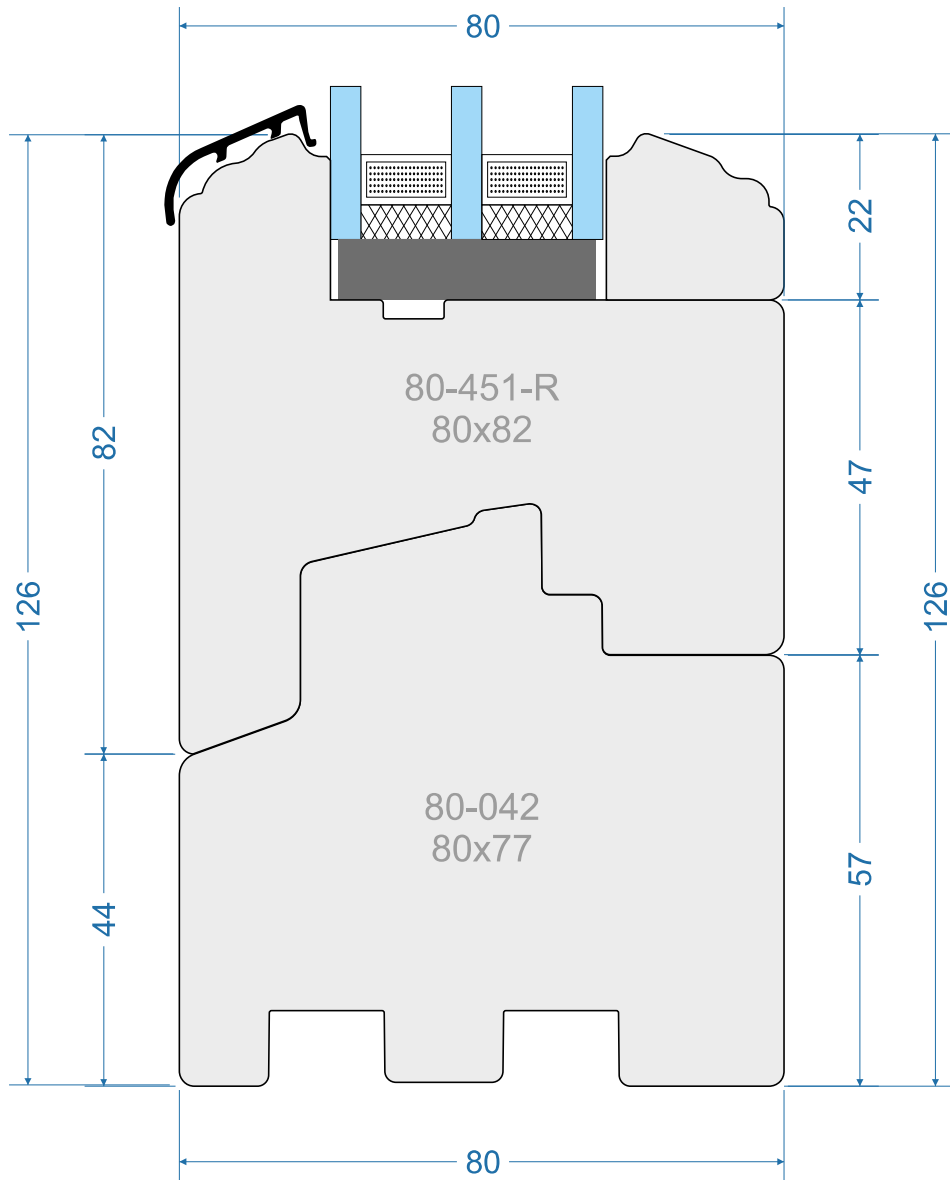



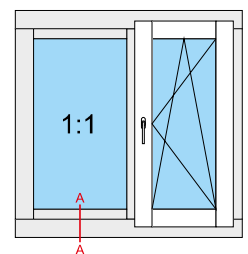



-  Wyrównanie dolne
-  Bottom alignment
-  Alignement en bas
-  Allineamento inferiore
-  Ausrichtung nach unten

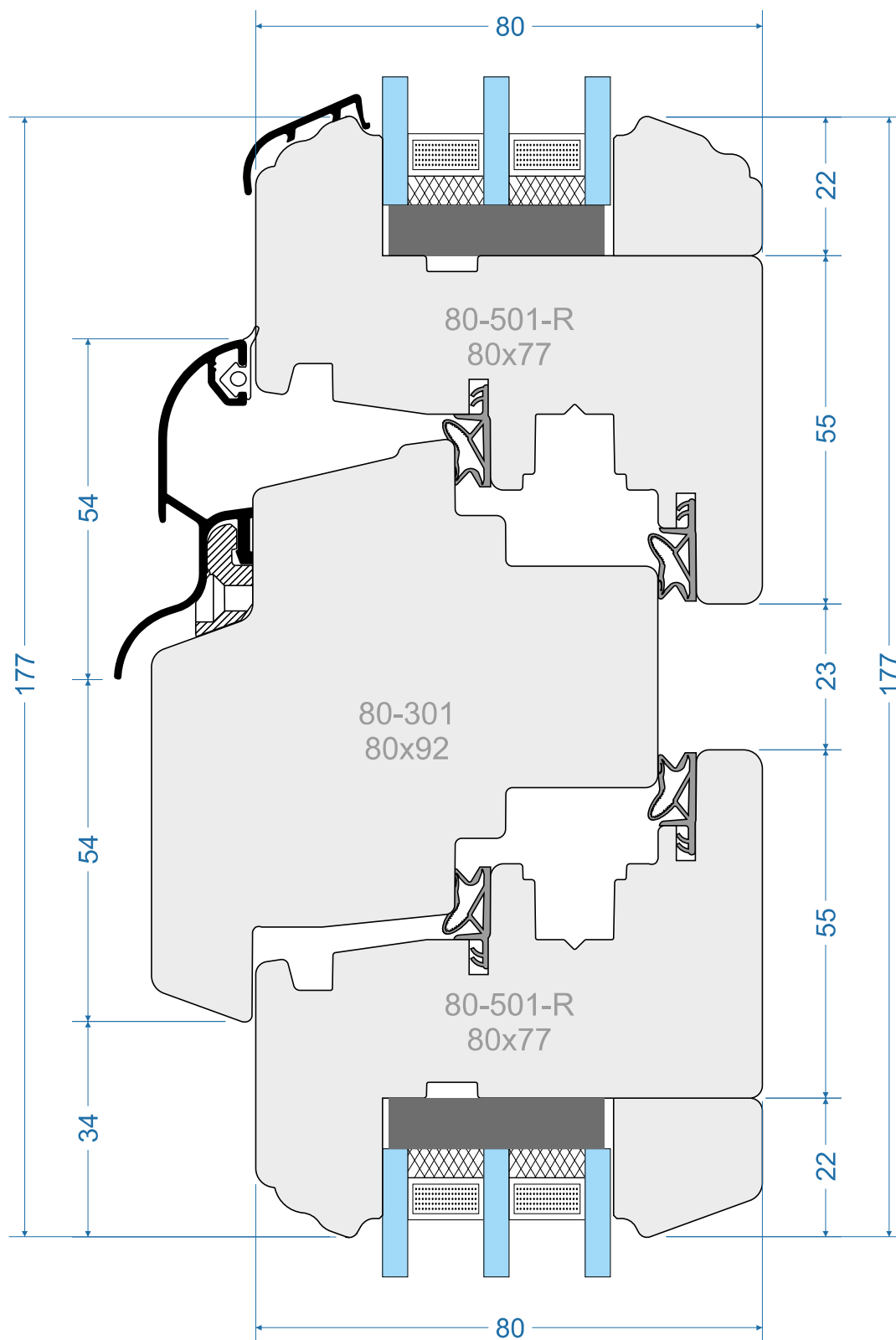

out

in



-  Słupek poziomy - skrzydło + skrzydło
-  Horizontal post - sash + sash
-  Traverse - ouvrant + ouvrant
-  Montante orizzontale - anta + anta
-  Horizontaler Pfosten - Flügel + Flügel

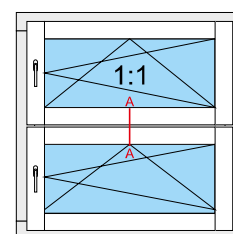

ENR-80-R-0021

Energio 80mm „S”

Energio 80mm „R”

Energio 80mm Classic „S”

Energio 80mm Classic „R”





Passiv 92mm „S”

Passiv 92mm „R”

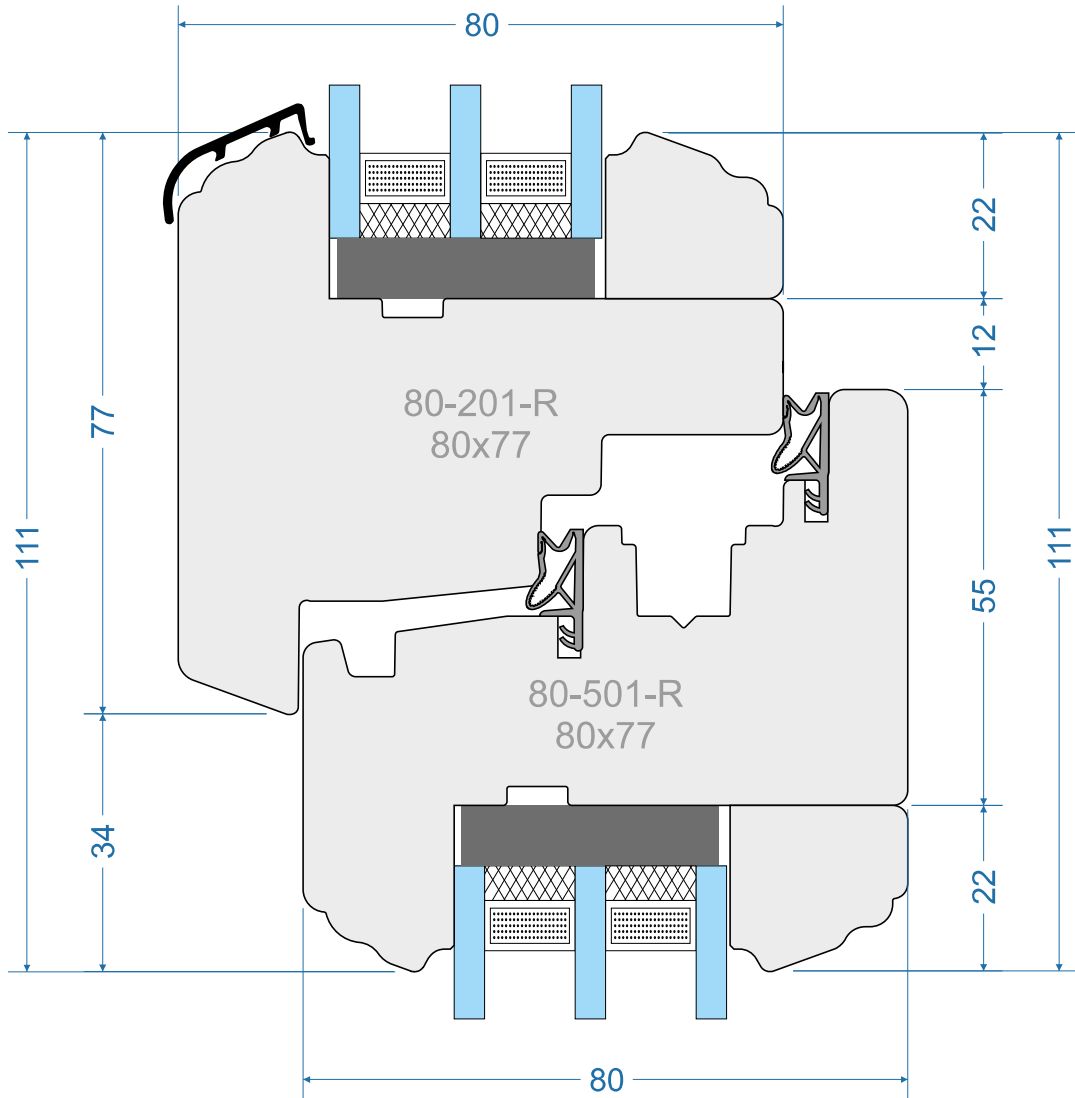
out

in





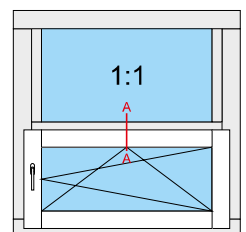



-  Słupek poziomy - fix + skrzydło
-  Horizontal post - fix + sash
-  Traverse - fixe + ouvrant
-  Montante orizzontale - fisso + anta
-  Horizontaler Pfosten - Fix + Flügel

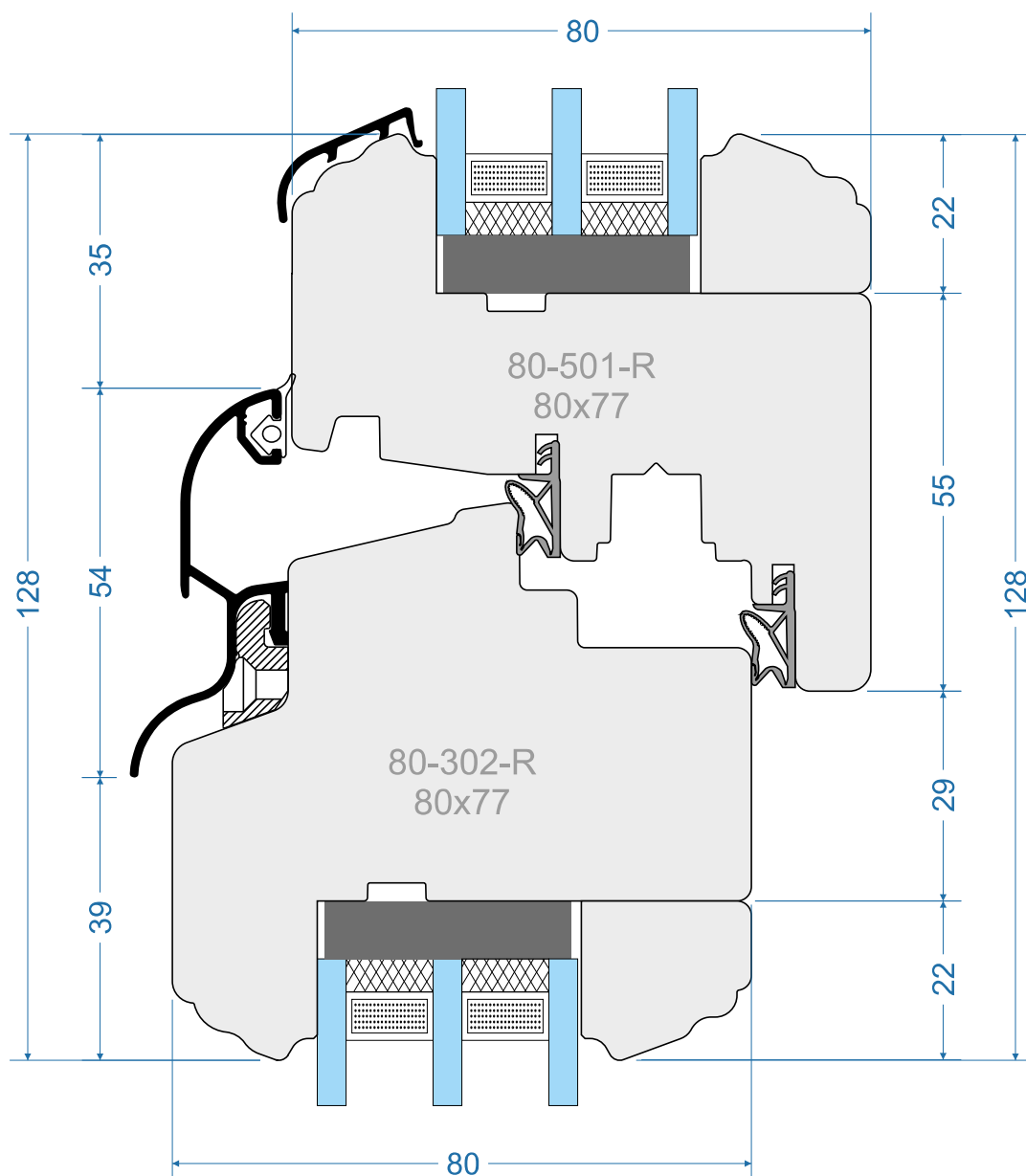

out

in



-  Słupek poziomy - skrzydło + fix
-  Horizontal post - sash + fix
-  Traverse- ouvrant + fixe
-  Montante orizzontale - anta + fisso
-  Horizontaler Pfosten - Flügel + Fix

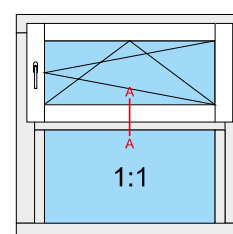

ENR-80-R-0023

Energio 80mm „S”

Energio 80mm „R”

Energio 80mm Classik „S”

Energio 80mm Classik „R”

Passiv 92mm „S”

Passiv 92mm „R”

Energio 80mm „S”

Energio 80mm „R”

Energio 80mm Classik „S”

Energio 80mm Classik „R”

Passiv 92mm „S”

Passiv 92mm „R”

out

in

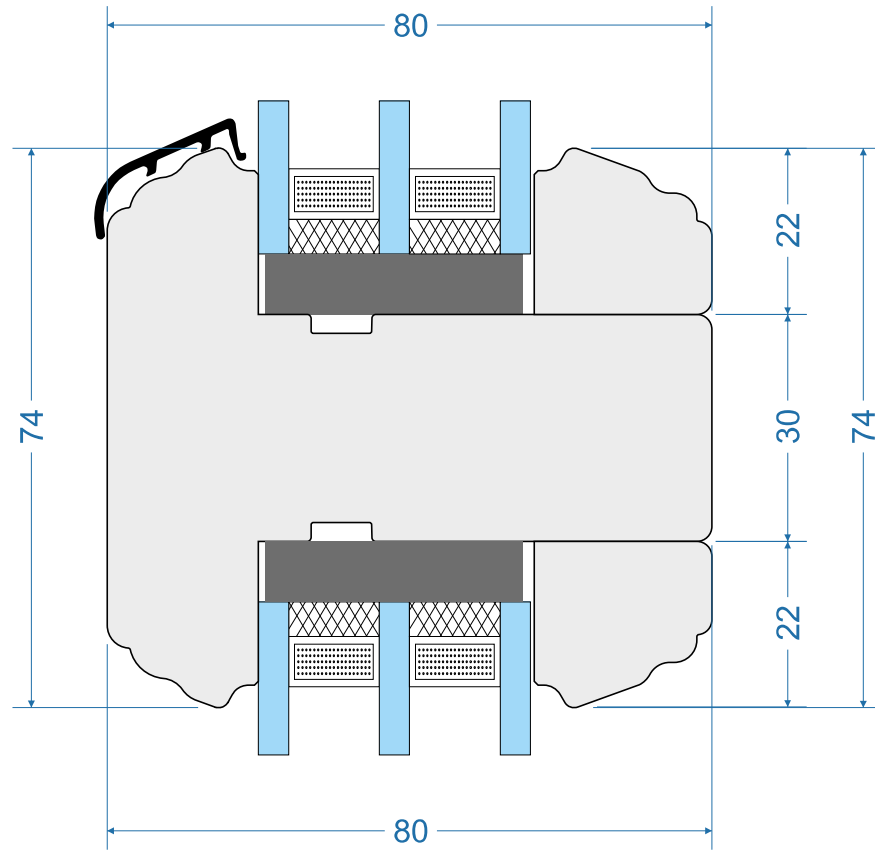

-  Poprzeczka
-  Bar
-  Traversine
-  Traverso
-  Bar

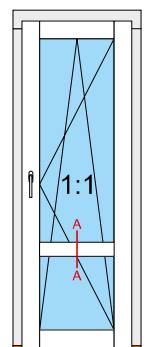





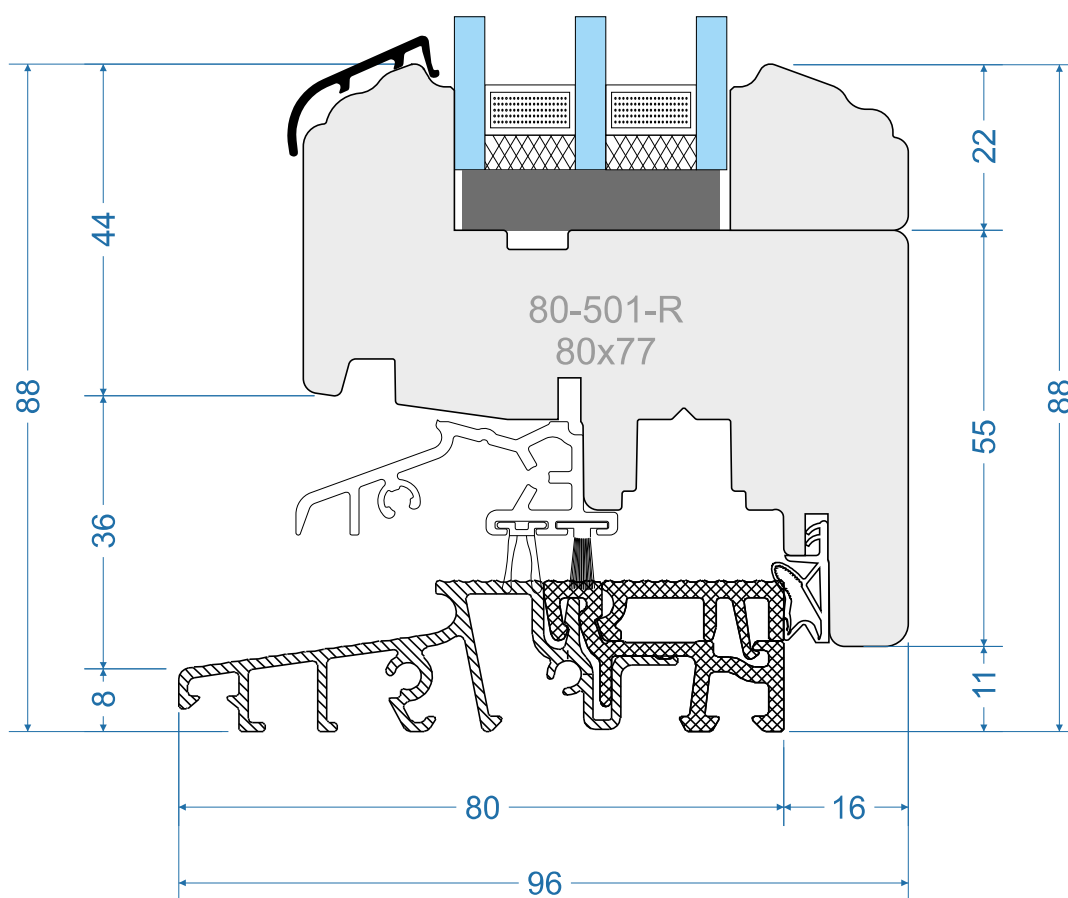

out

in



-  Próg aluminiowy + skrzydło 77mm
-  Aluminum threshold + sash 77mm
-  Seuil en aluminium + châssis 77mm
-  Soglia in alluminio + anta 77mm
-  Aluminiumschwelle + Flügel 77mm

ENR-80-R-0025

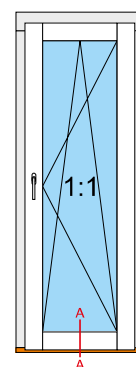

Energio 80mm „S”

Energio 80mm „R”

Energio 80mm Classik „S”

Energio 80mm Classik „R”





Passiv 92mm „S”

Passiv 92mm „R”

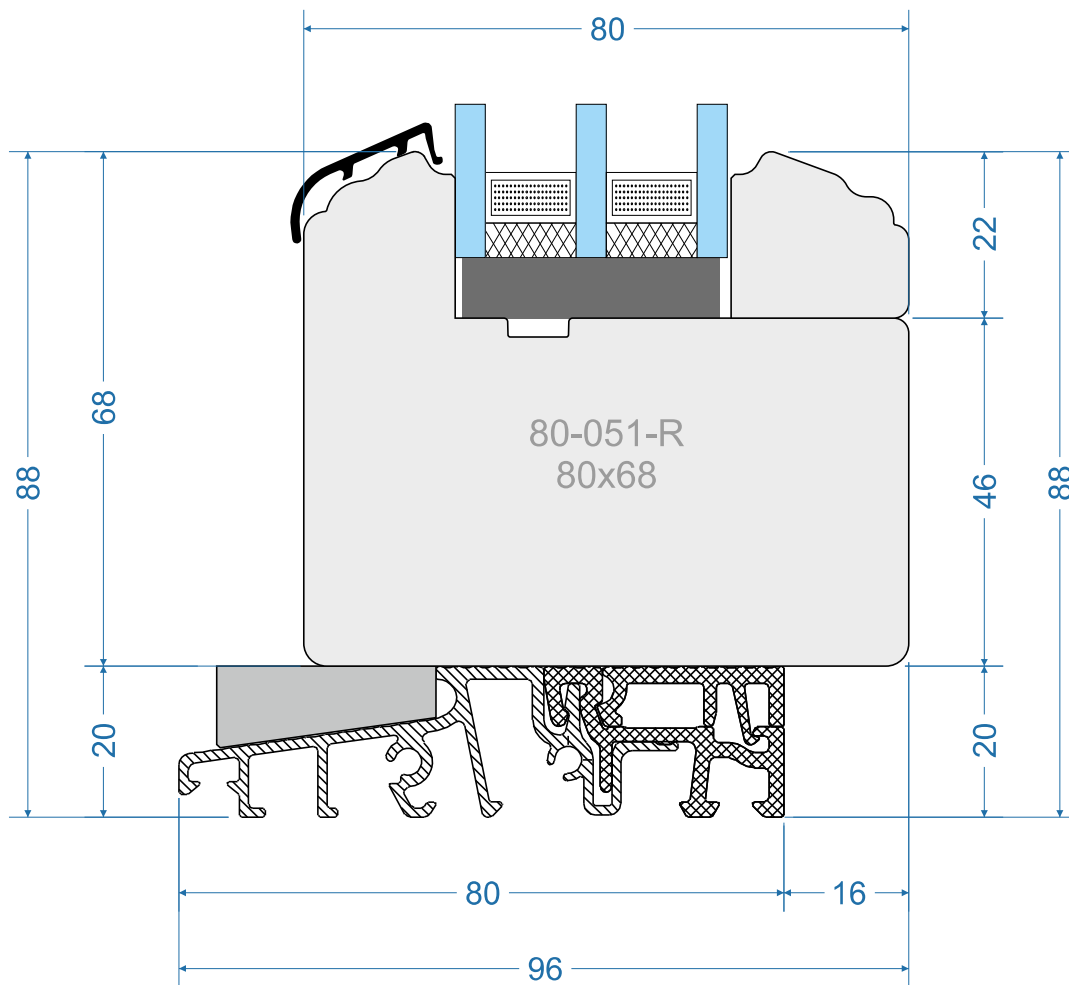
out

in



-  Wyrównanie do „Próg aluminiowy + skrzydło 77mm”
-  Alignment to „Aluminum threshold + sash 77mm”
-  Alignement sur le „Seuil en aluminium + châssis 77mm”
-  Allineamento alla „Soglia in alluminio + anta 77mm”
-  Ausrichtung an der „Aluminiumschwelle + Flügel 77mm”

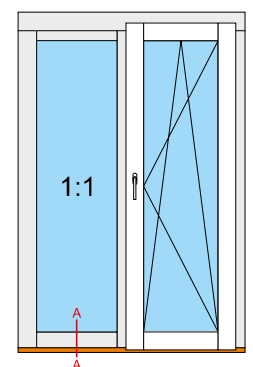



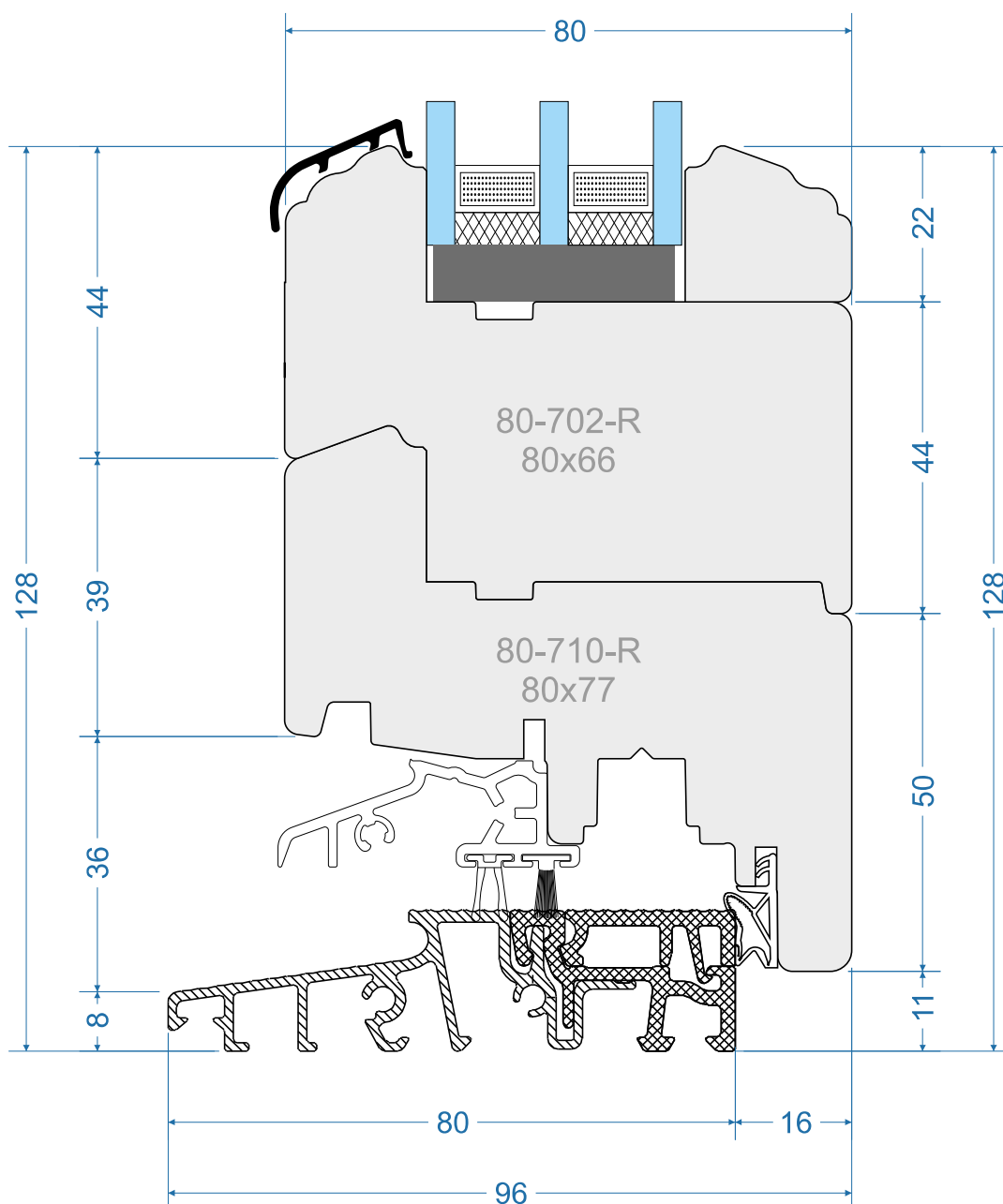

ENR-80-R-0026

out

in



-  Próg aluminiowy + skrzydło 77mm + cokół 66mm
-  Aluminum threshold + sash 77mm + plinth 66mm
-  Seuil en aluminium + châssis 77mm + socle 66mm
-  Soglia in alluminio + anta 77mm + zoccolo 66mm
-  Aluminiumschwelle + Flügel 77mm + Sockel 66mm

ENR-80-R-0027

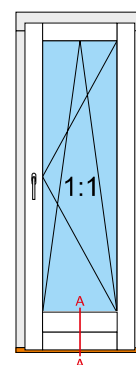

Energio 80mm „S”

Energio 80mm „R”

Energio 80mm Classik „S”

Energio 80mm Classik „R”





Passiv 92mm „S”

Passiv 92mm „R”

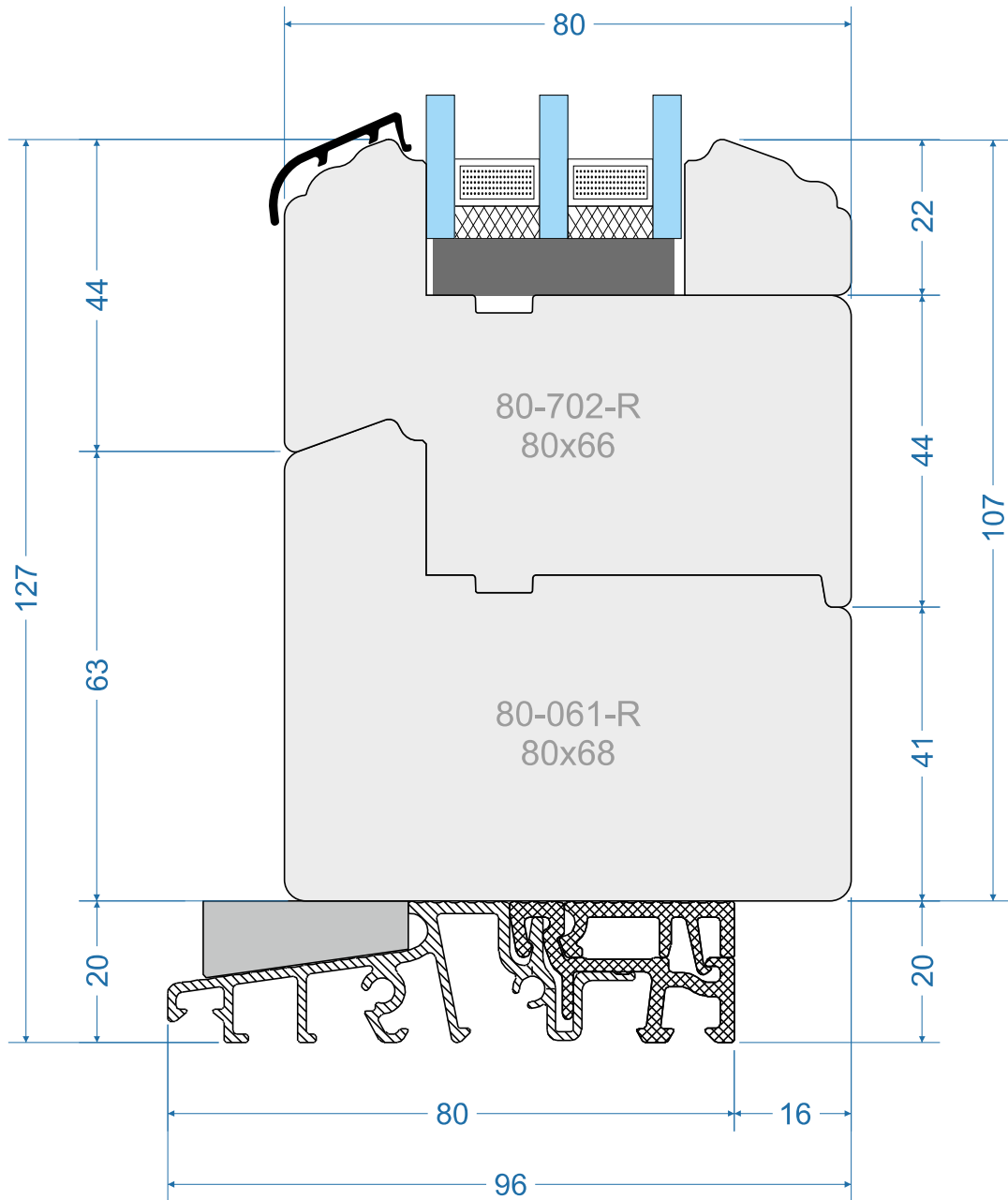
out

in



-  Wyrównanie do „Próg aluminiowy + skrzydło 77mm + cokół 66mm”
-  Alignment to „Aluminum threshold + sash 77mm + plinth 66mm”
-  Alignement sur le „Seuil en aluminium + châssis 77mm + socle 66mm”
-  Allineamento alla „Soglia in alluminio + anta 77mm + zoccolo 66mm”
-  Ausrichtung an der „Aluminiumschwelle + Flügel 77mm + Sockel 66mm”

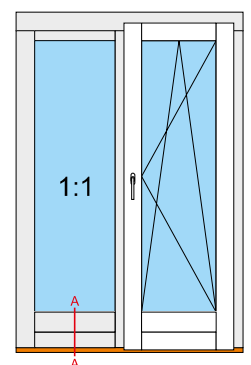



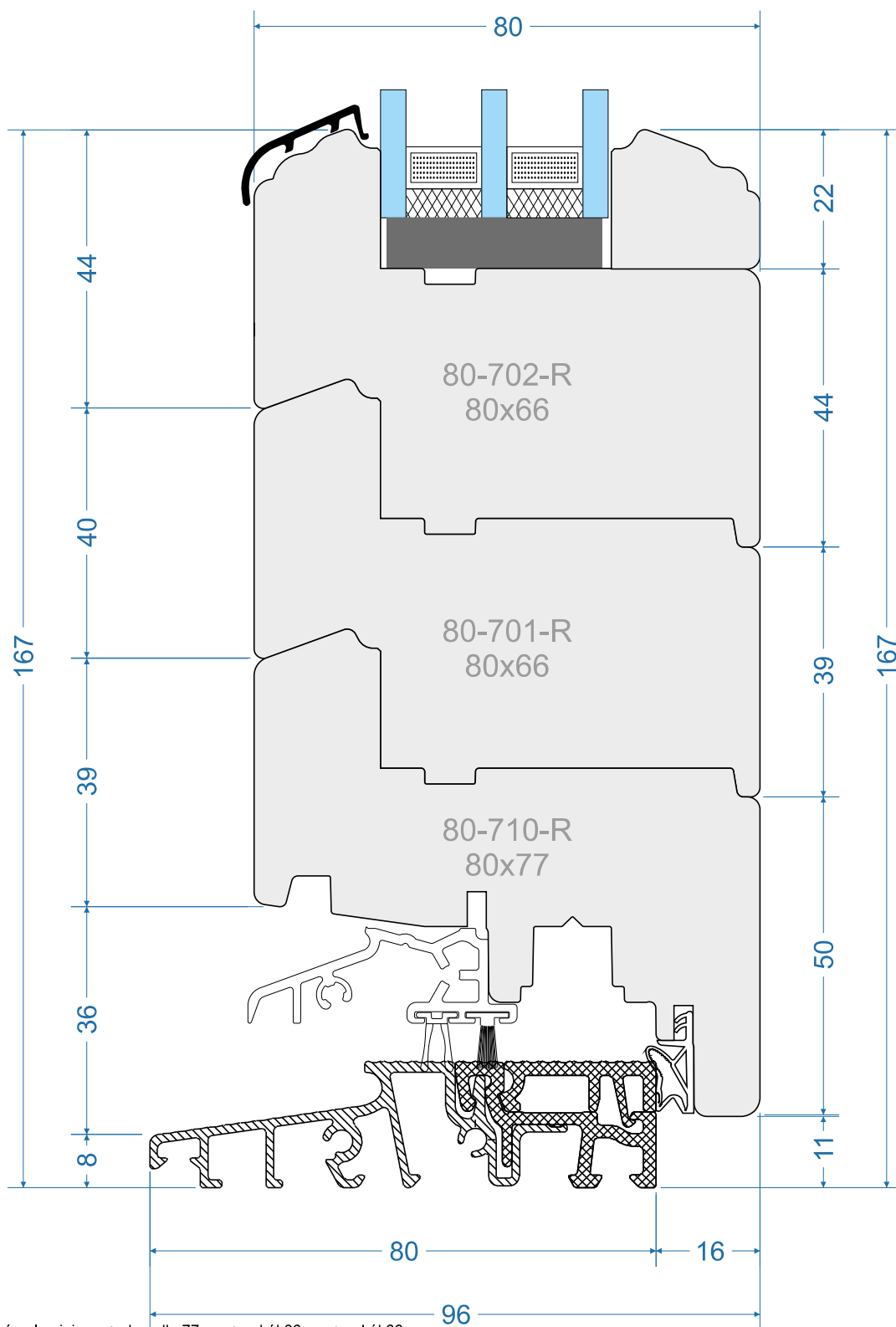

ENR-80-R-0028

out

in



-  Próg aluminiowy + skrzydło 77mm + cokół 66mm + cokół 66mm
-  Aluminum threshold + sash 77mm + plinth 66mm + plinth 66mm
-  Seuil en aluminium + châssis 77mm + socle 66mm + socle 66mm
-  Soglia in alluminio + anta 77mm + zoccolo 66mm + zoccolo 66mm
-  Aluminiumschwelle + Flügel 77mm + Sockel 66mm + Sockel 66mm

ENR-80-R-0029

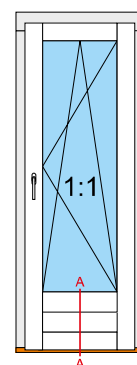

Energio 80mm „S”

Energio 80mm „R”

Energio 80mm Classik „S”

Energio 80mm Classik „R”





Passiv 92mm „S”

Passiv 92mm „R”

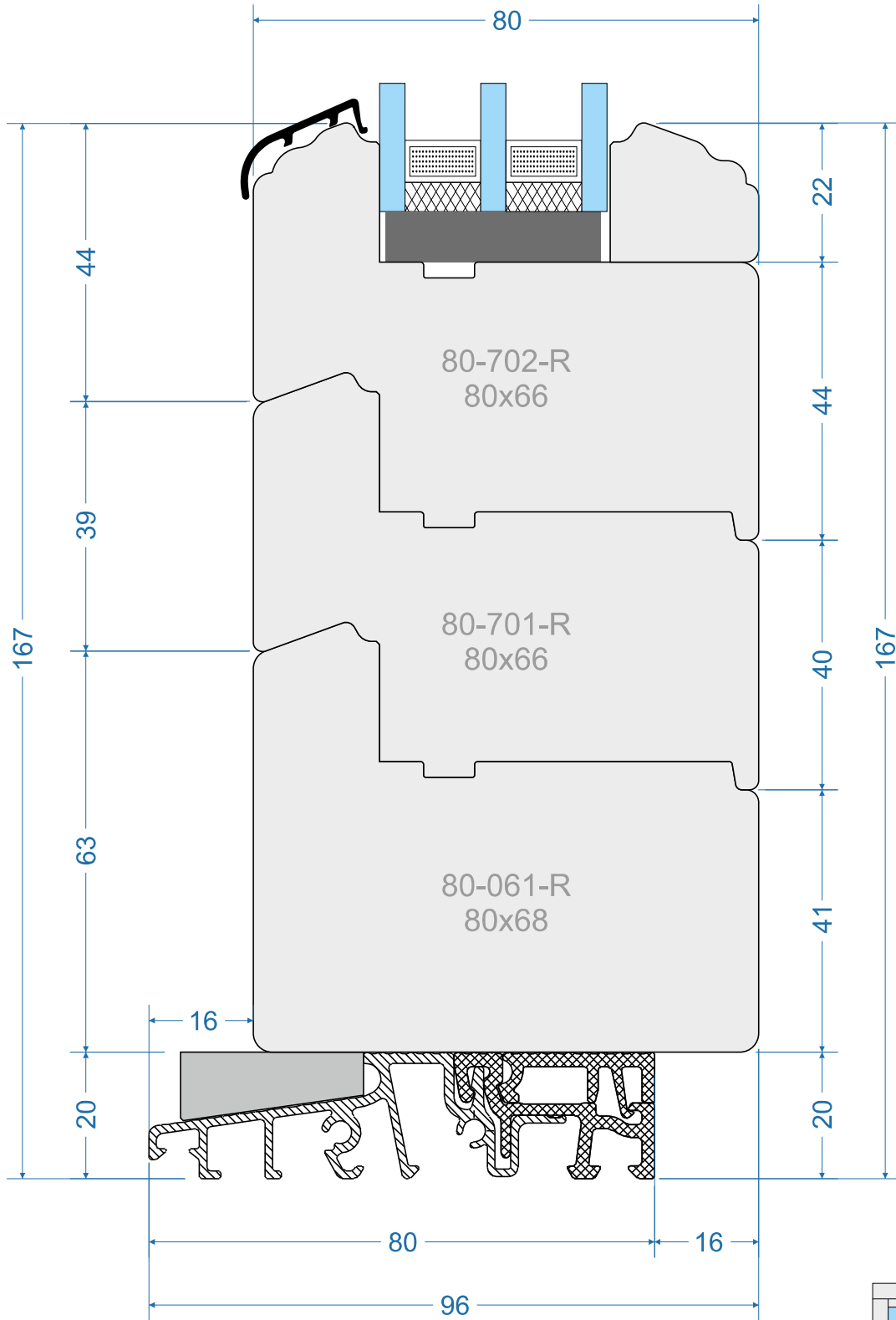
out

in





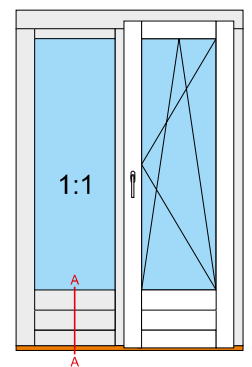



-  Wyrównanie do „Próg aluminiowy + skrzydło 77mm + cokół 66mm + cokół 66mm”
-  Alignment to „Aluminum threshold + sash 77mm + plinth 66mm + plinth 66mm”
-  Alignement sur le „Seuil en aluminium + châssis 77mm + socle 66mm + socle 66mm”
-  Allineamento alla „Soglia in alluminio + anta 77mm + zoccolo 66mm + zoccolo 66mm”
-  Ausrichtung an der „Aluminiumschwelle + Flügel 77mm + Sockel 66mm + Sockel 66mm”

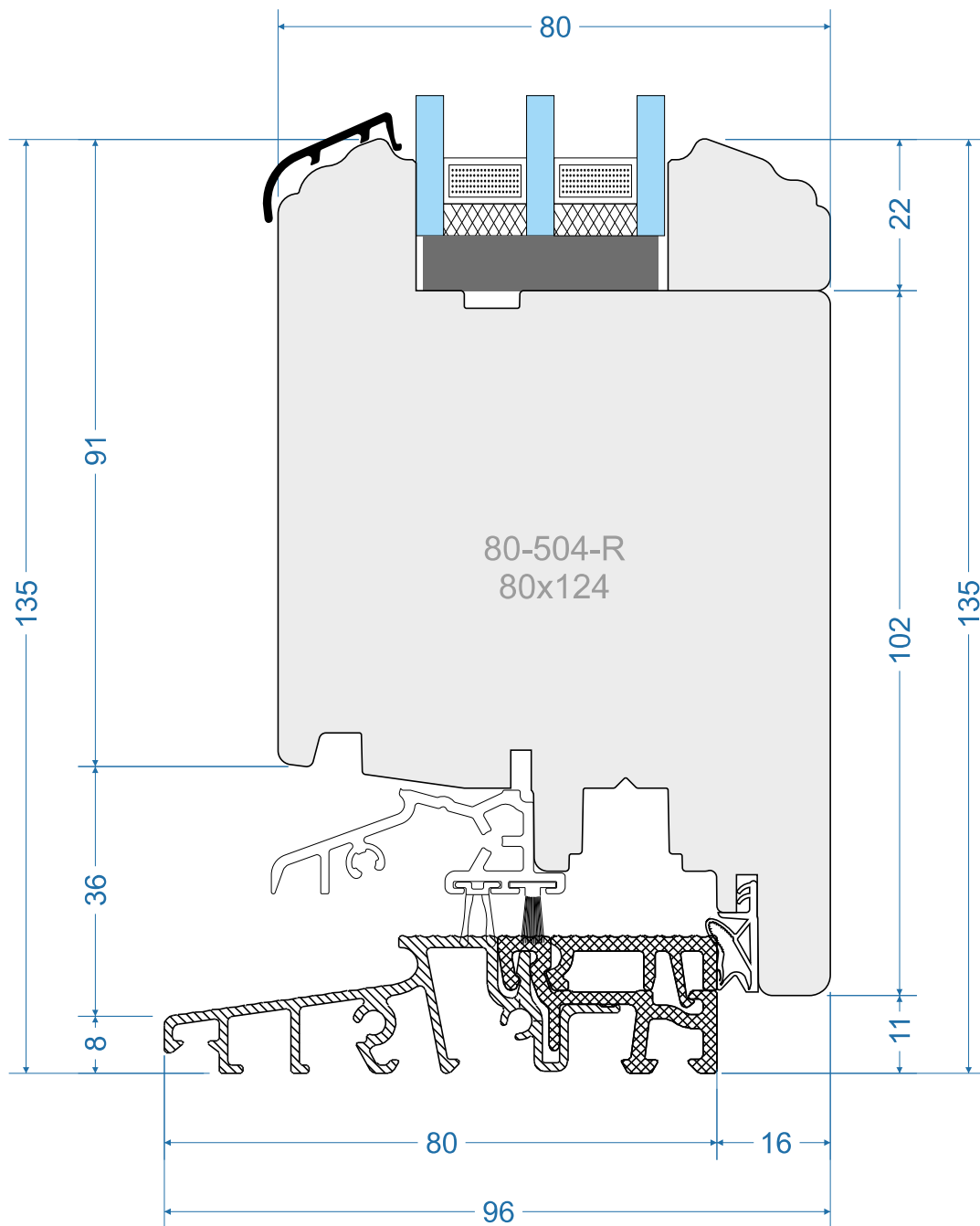

out

in



-  Próg aluminiowy + skrzydło 124mm
-  Aluminum threshold + sash 124mm
-  Seuil en aluminium + ouvrant 124mm
-  Soglia in alluminio + anta 124mm
-  Aluminiumschwelle + Flügel 124mm

ENR-80-R-0031

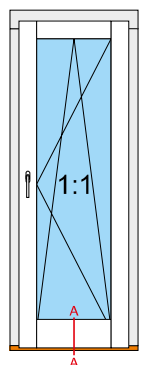

Energio 80mm „S”

Energio 80mm „R”

Energio 80mm Classic „S”

Energio 80mm Classic „R”





Passiv 92mm „S”

Passiv 92mm „R”

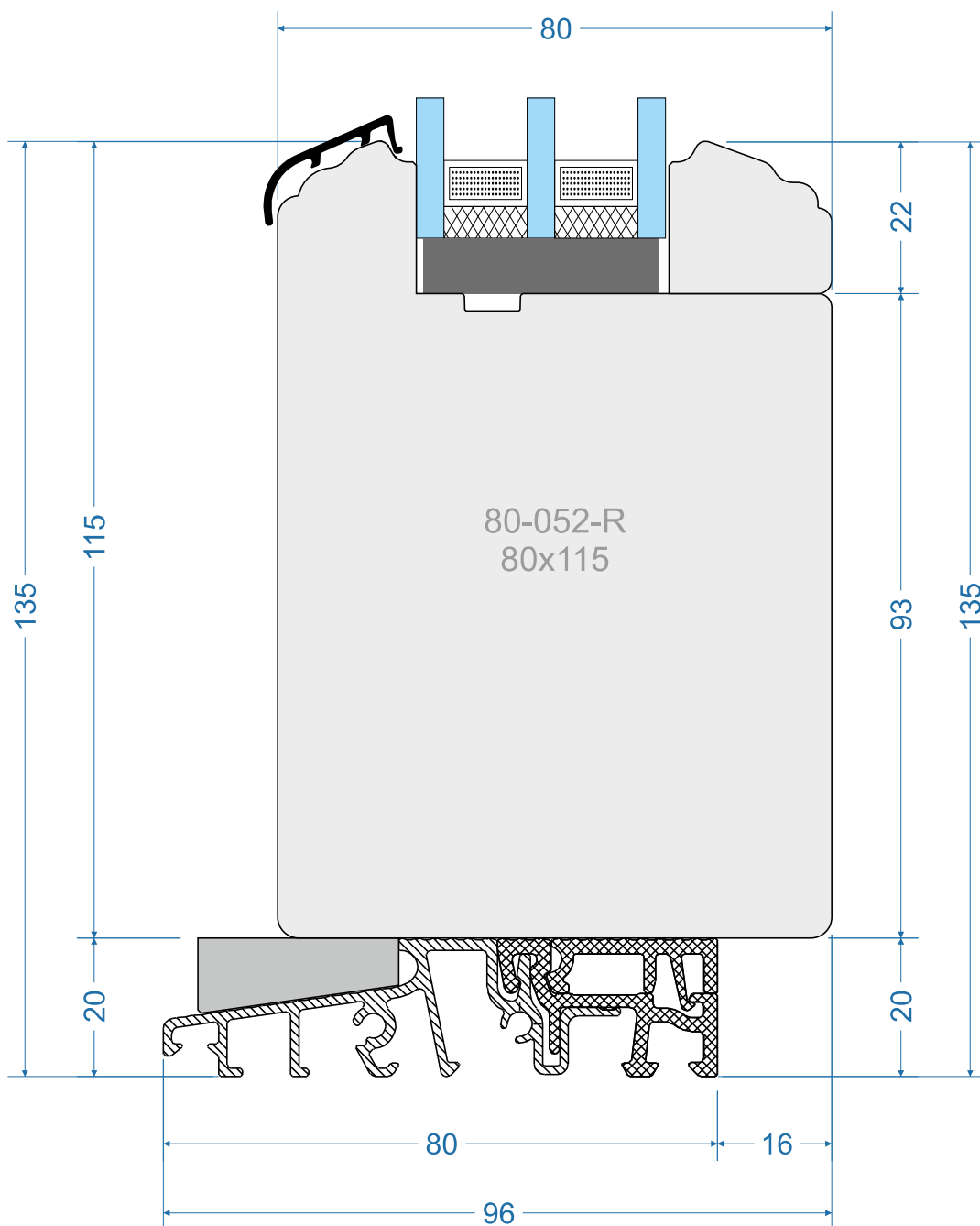
out

in



-  Wyrównanie do „Próg aluminiowy + skrzydło 124mm”
-  Alignment to „Aluminum threshold + sash 124mm”
-  Alignement sur le „Seuil en aluminium + ouvrant 124mm”
-  Allineamento alla „Soglia in alluminio + anta 124mm”
-  Ausrichtung an der „Aluminiumschwelle + Flügel 124mm”

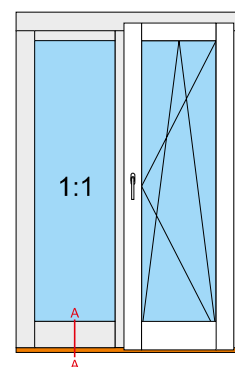





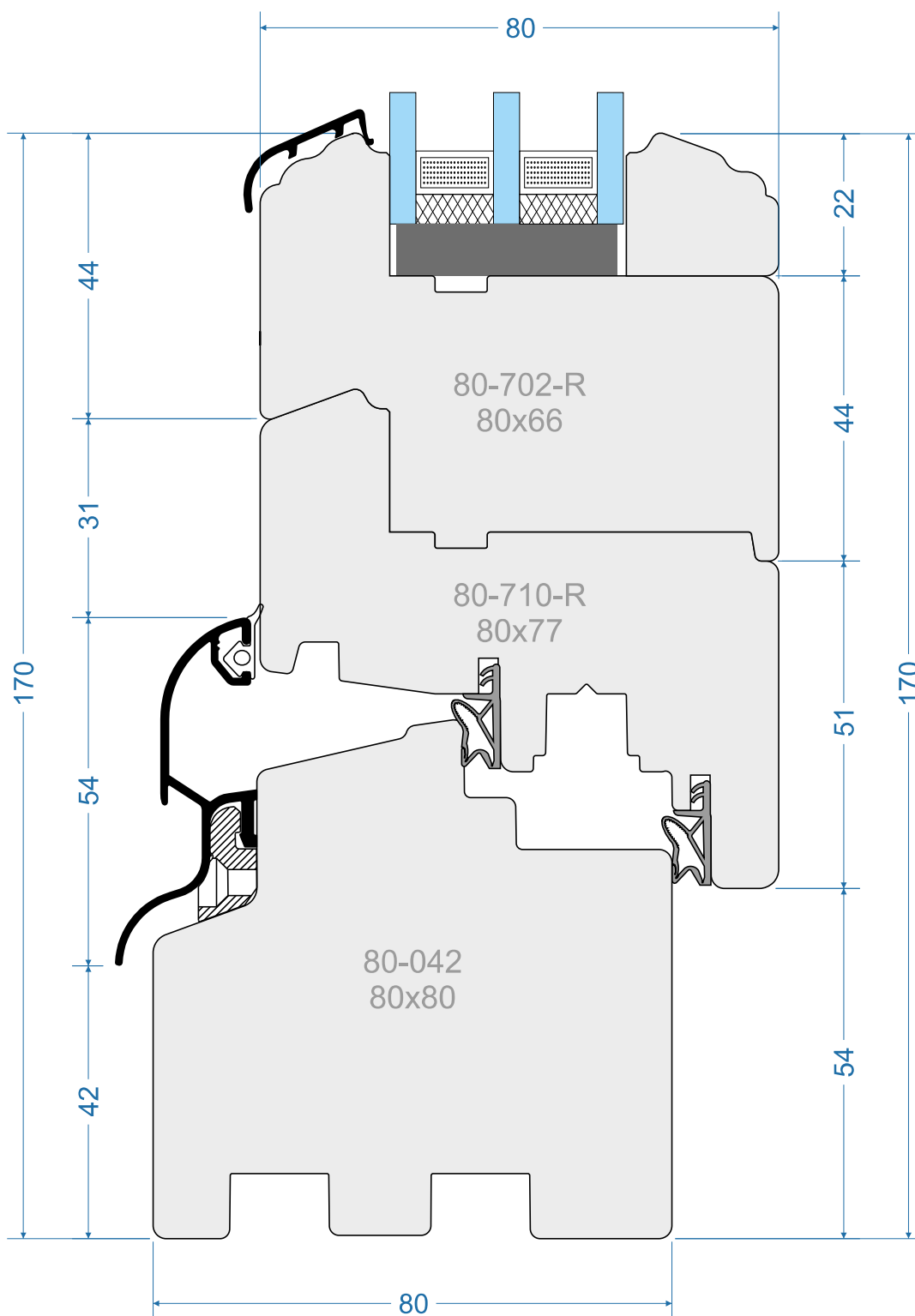

out

in



-  Rama + skrzydło 77mm + cokół 66mm
-  Frame + sash 77mm + plinth 66mm
-  Cadre + châssis 77mm + socle 66mm
-  Telaio + anta 77mm + zoccolo 66mm
-  Rahmen + Flügel 77mm + Sockel 66mm

ENR-80-R-0033

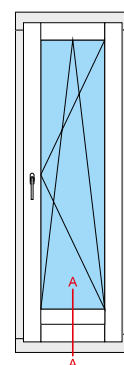

Energio 80mm „S”

Energio 80mm „R”

Energio 80mm Classic „S”

Energio 80mm Classic „R”





Passiv 92mm „S”

Passiv 92mm „R”

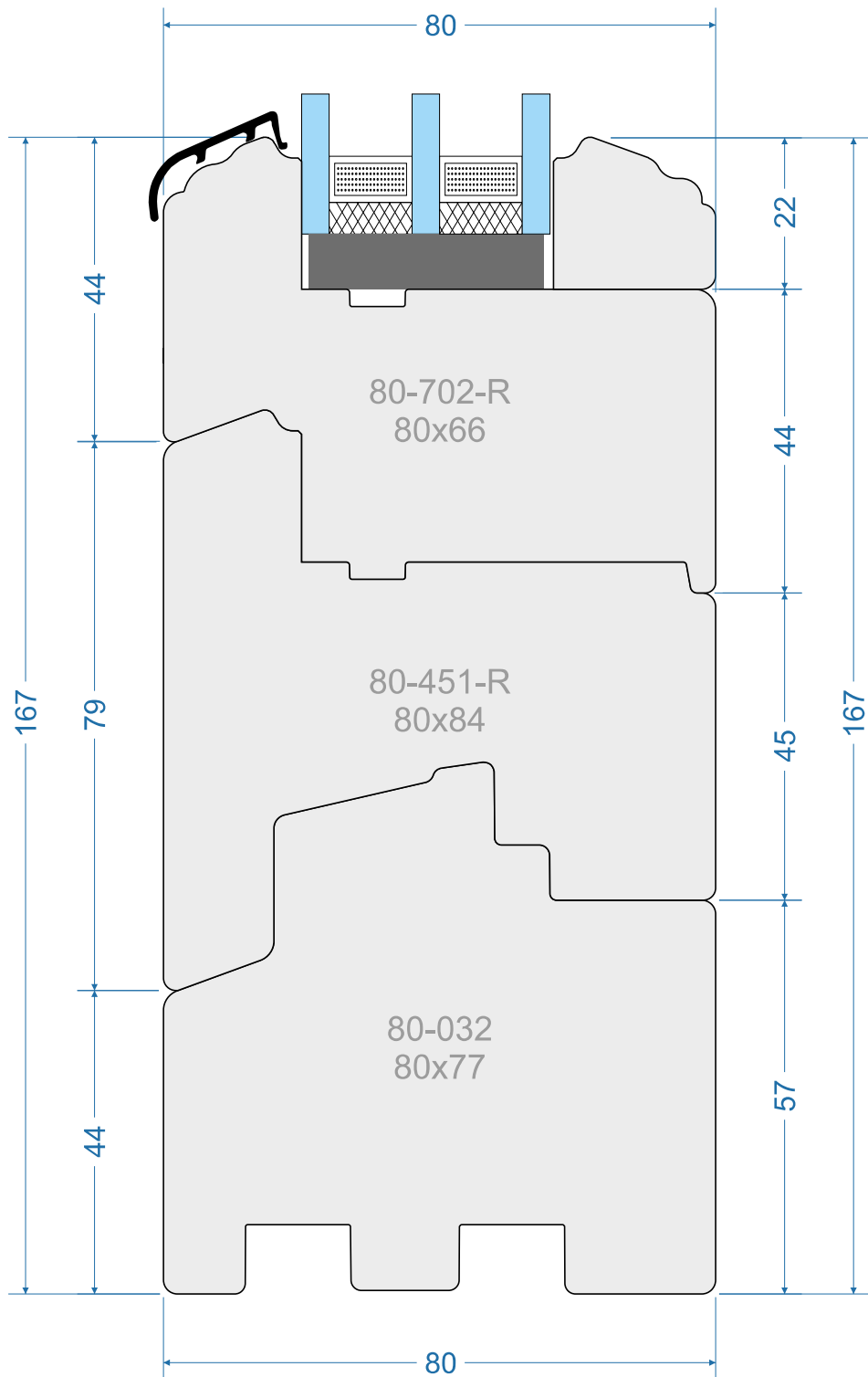
out

in



-  Wyrównanie do „Rama + skrzydło 77mm + cokół 66mm”
-  Alignment to „Frame + sash 77mm + plinth 66mm”
-  Alignement sur le „Cadre + châssis 77mm + socle 66mm”
-  Allineamento alla „Telaio + anta 77mm + zoccolo 66mm”
-  Ausrichtung an der „Rahmen + Flügel 77mm + Sockel 66mm”

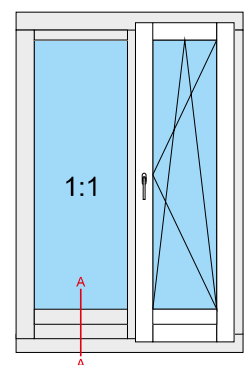

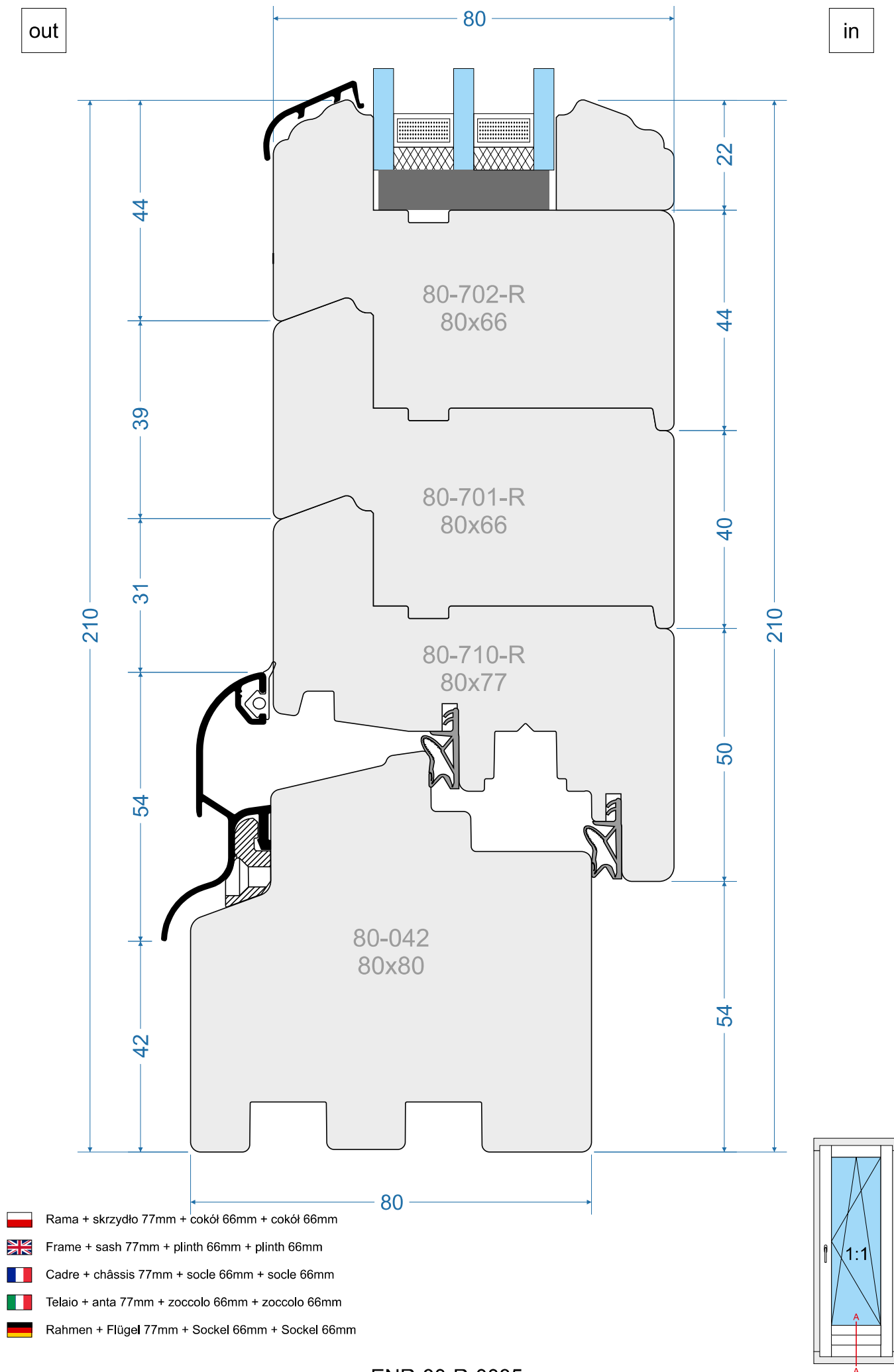

ENR-80-R-0035

Energio 80mm „S”

Energio 80mm „R”

Energio 80mm Classik „S”

Energio 80mm Classik „R”

Passiv 92mm „S”

Passiv 92mm „R”

- Energio 80mm „S”
- Energio 80mm „R”
- Energio 80mm Classic „S”
- Energio 80mm Classic „R”
- Passiv 92mm „S”
- Passiv 92mm „R”

out

in

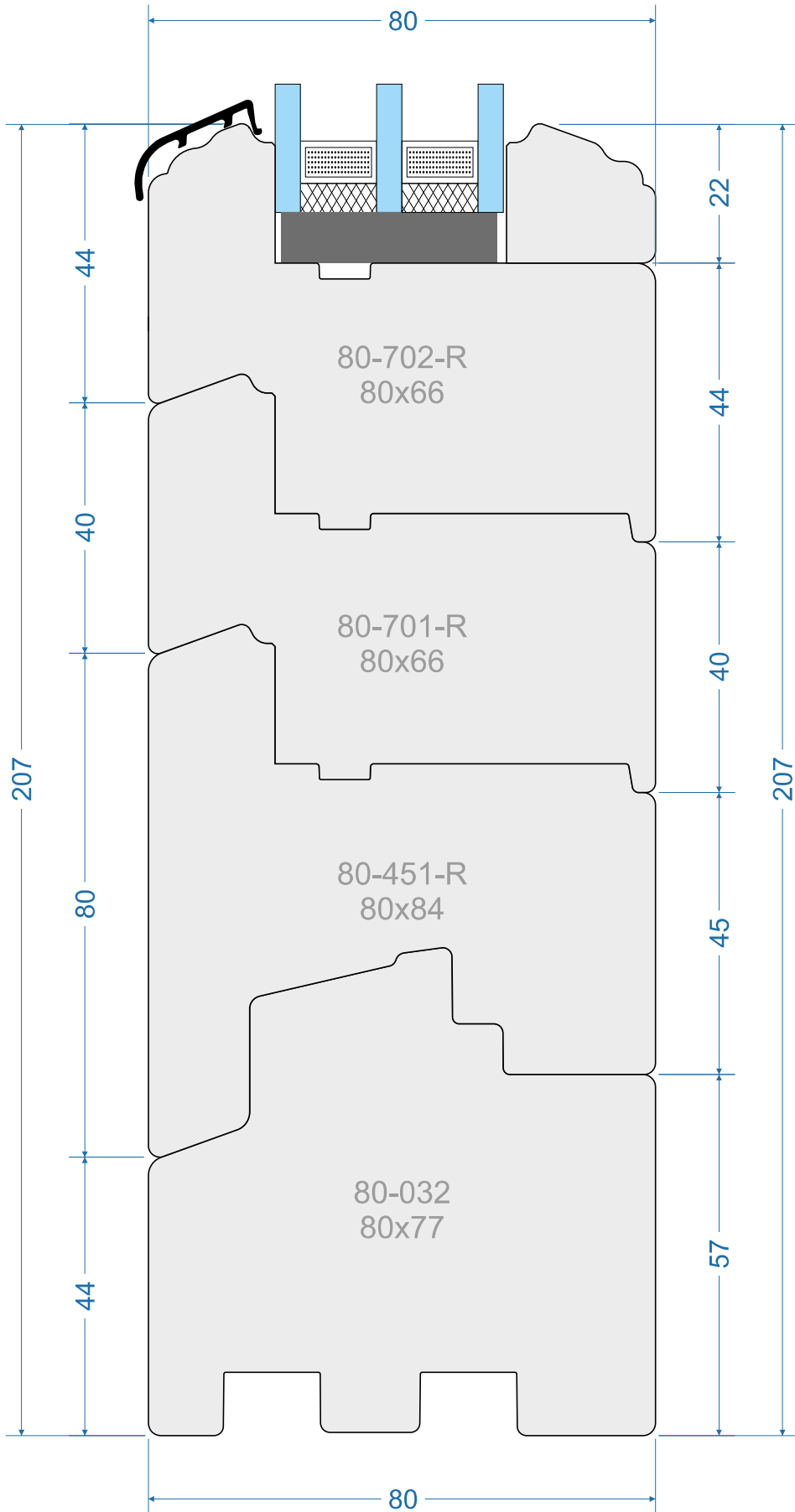

- Wyrównanie do „Rama + skrzydło 77mm + cokół 66mm + cokół 66mm”
- Alignment to „Frame + sash 77mm + plinth 66mm + plinth 66mm”
- Alignement sur le „Cadre + châssis 77mm + socle 66mm + socle 66mm”
- Allineamento alla „Telaio + anta 77mm + zoccolo 66mm + zoccolo 66mm”
- Ausrichtung an der „Rahmen + Flügel 77mm + Sockel 66mm + Sockel 66mm”

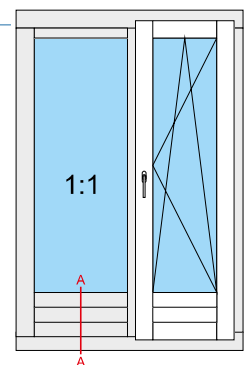

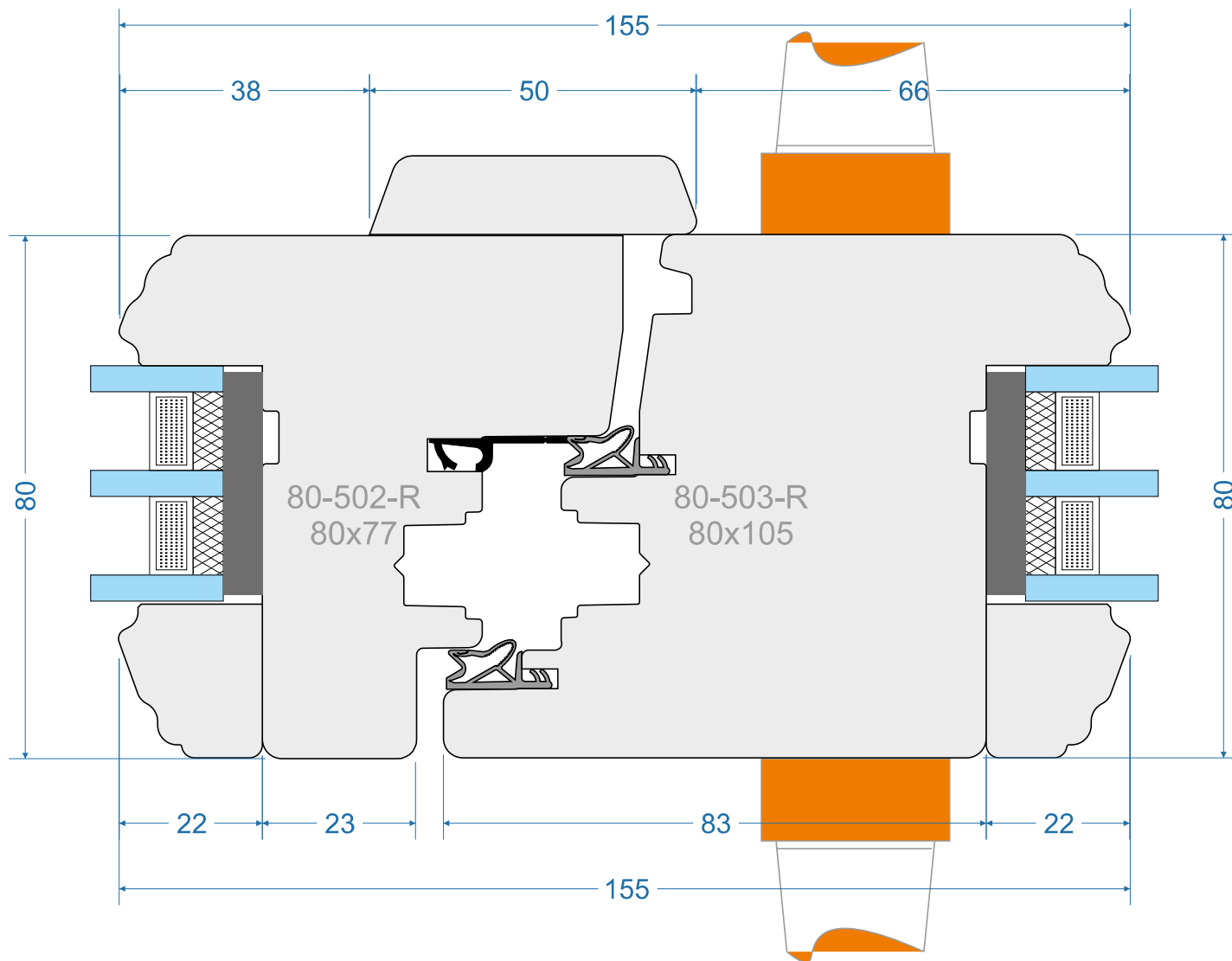





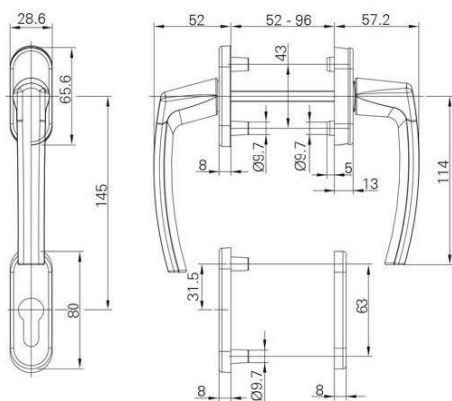

standard cylinder



cylinder with knob



-  Dwustronna klamka okienna
-  Double side window type handle
-  Poignée de fenêtre double face
-  Maniglia bifacciale per finestre
-  Doppelseitiger Fenster Griff

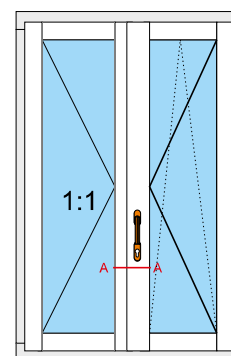

Energio 80mm „S”

Energio 80mm „R”

Energio 80mm Classik „S”

Energio 80mm Classik „R”

Passiv 92mm „S”

Passiv 92mm „R”

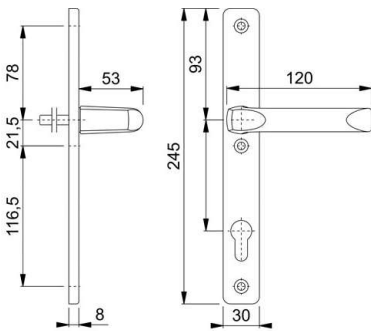
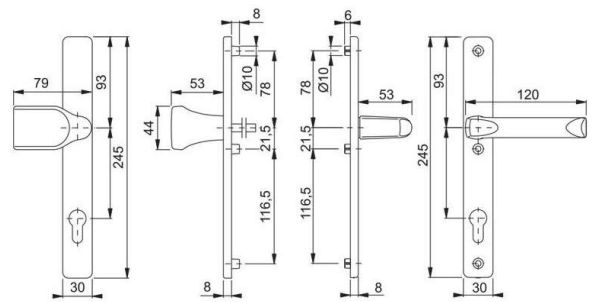
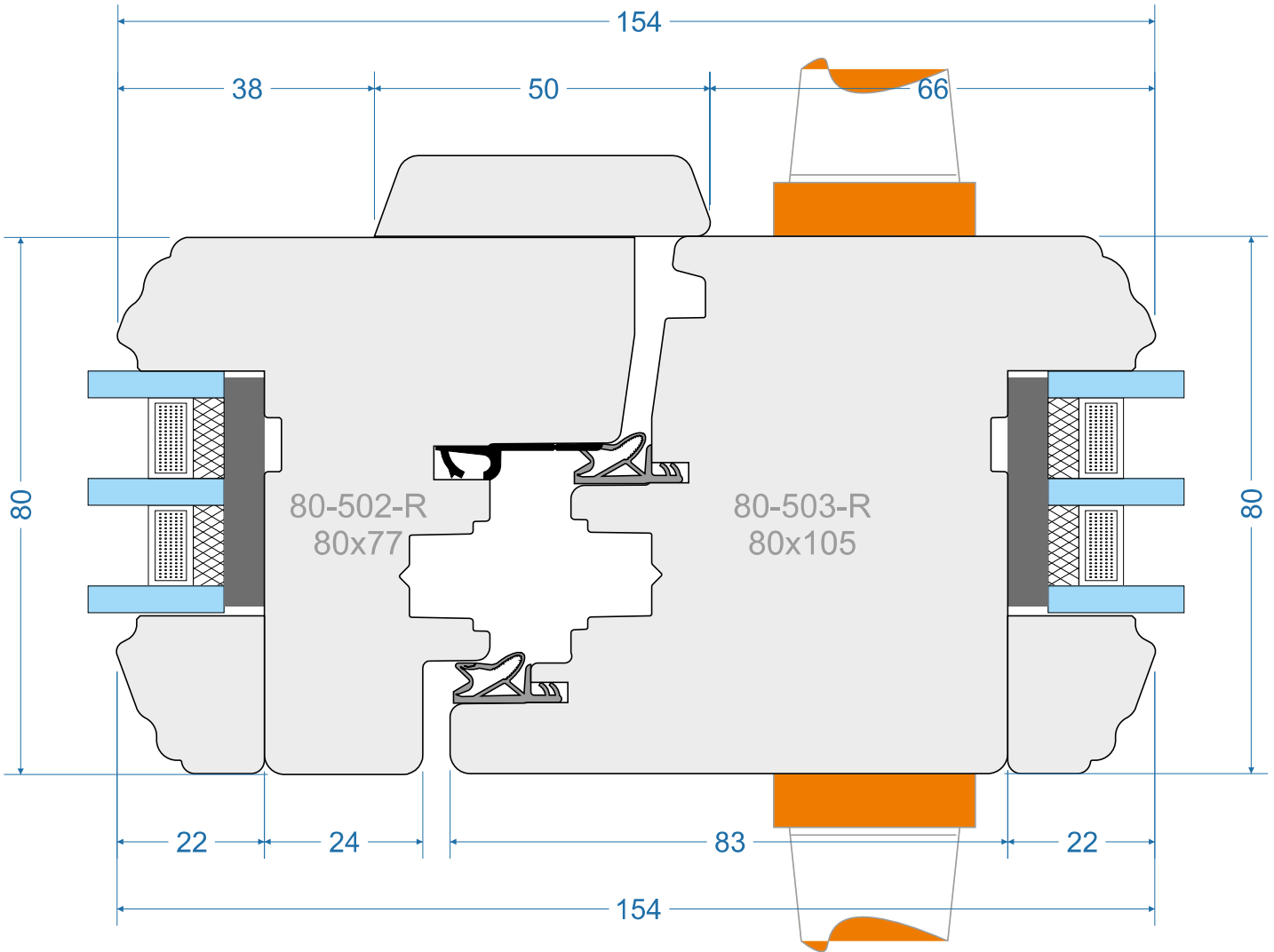





standard cylinder







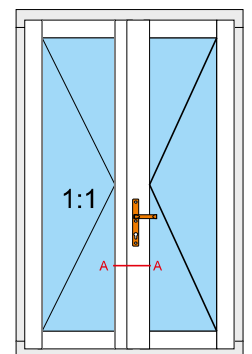

cylinder with knob

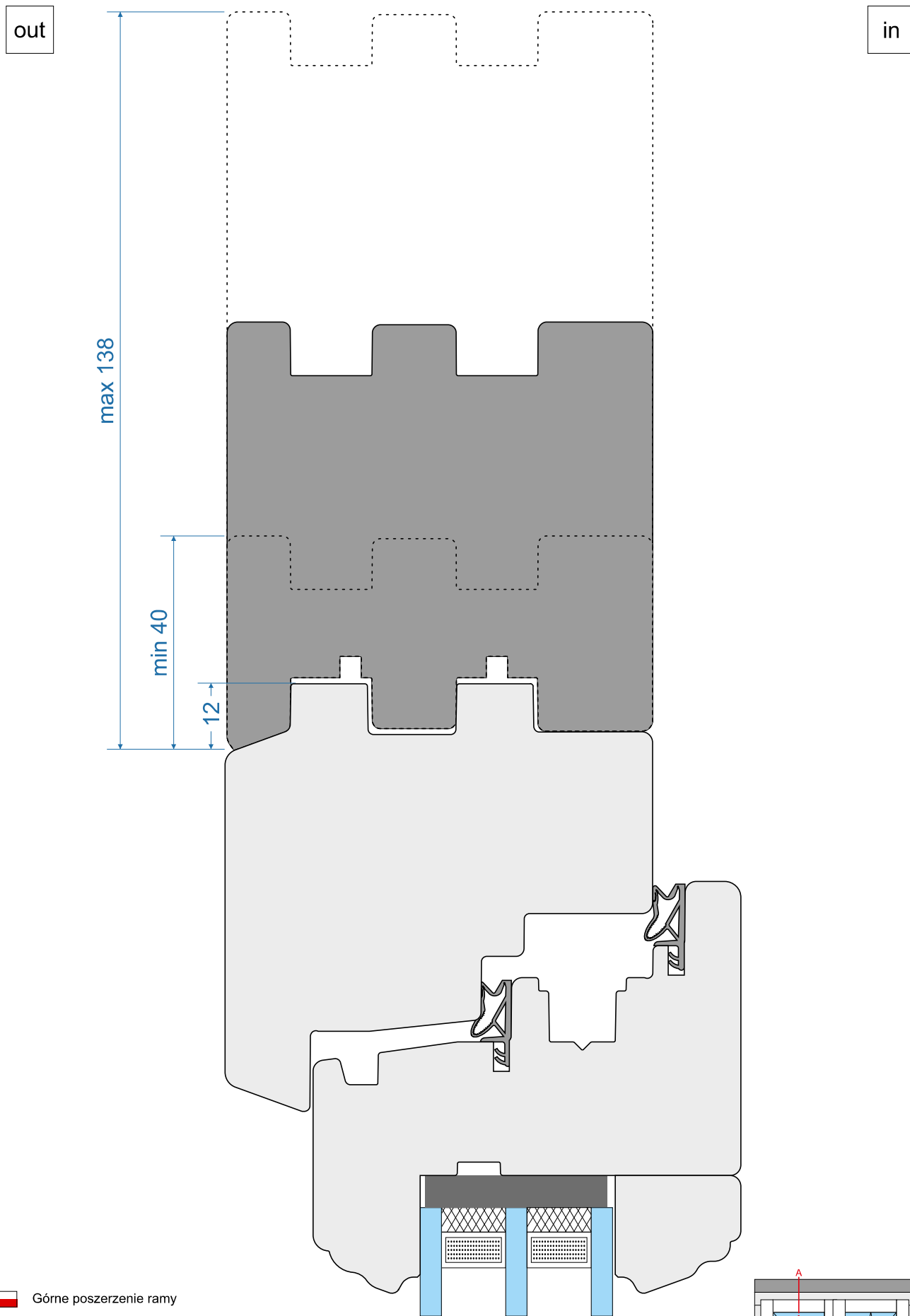

-  Dwustronna klamka drzwiowa
-  Double side door type handle
-  Poignée de Porte Fenêtre double face
-  Maniglia bifacciale per porte finestra
-  Doppelseitiger Tür Griff





-  Górne poszerzenie ramy
-  Upper frame extension
-  Élargissement supérieur du cadre
-  Estensione del telaio superiore
-  Obere Rahmenverbreiterung

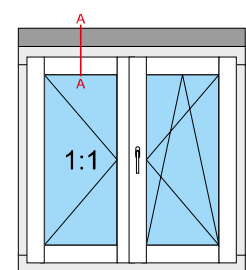

ENR-80-R-0039

Passiv 92mm „R”  
 Passiv 92mm „S”  
 Energo 80mm Classik „R”  
 Energo 80mm Classik „S”  
**Energo 80mm „R”**  
 Energo 80mm „S”

out

Energio 80mm „S”

Energio 80mm „R”

Energio 80mm Classik „S”



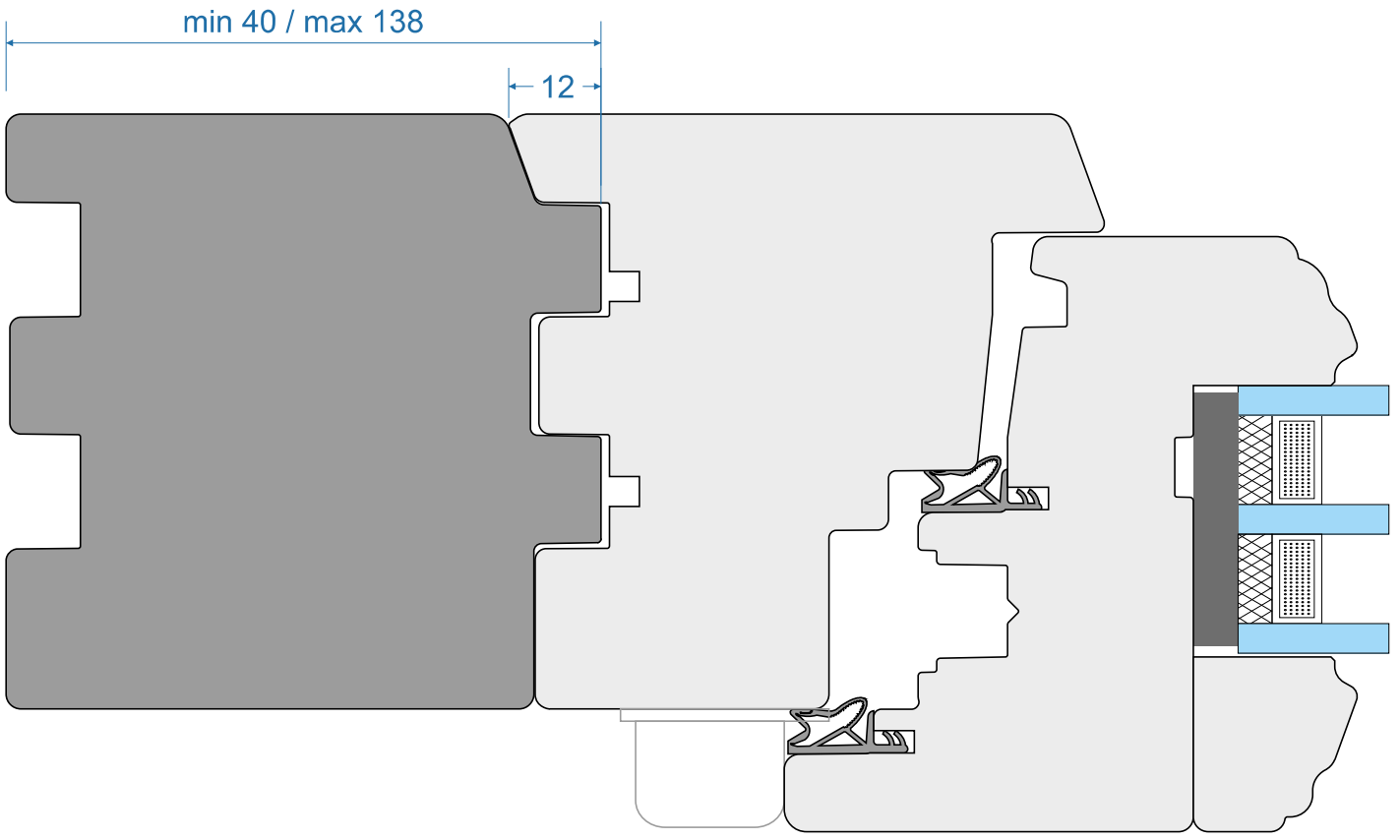

Energio 80mm Classik „R”

Passiv 92mm „S”

Passiv 92mm „R”



in

-  Boczne poszerzenie ramy
-  Side frame extension
-  Élargissement latéral du cadre
-  Estensione del telaio laterale
-  Seitliche Rahmenverbreitung

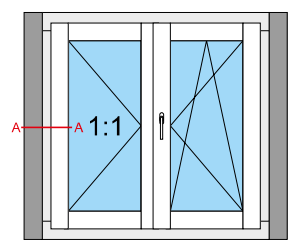





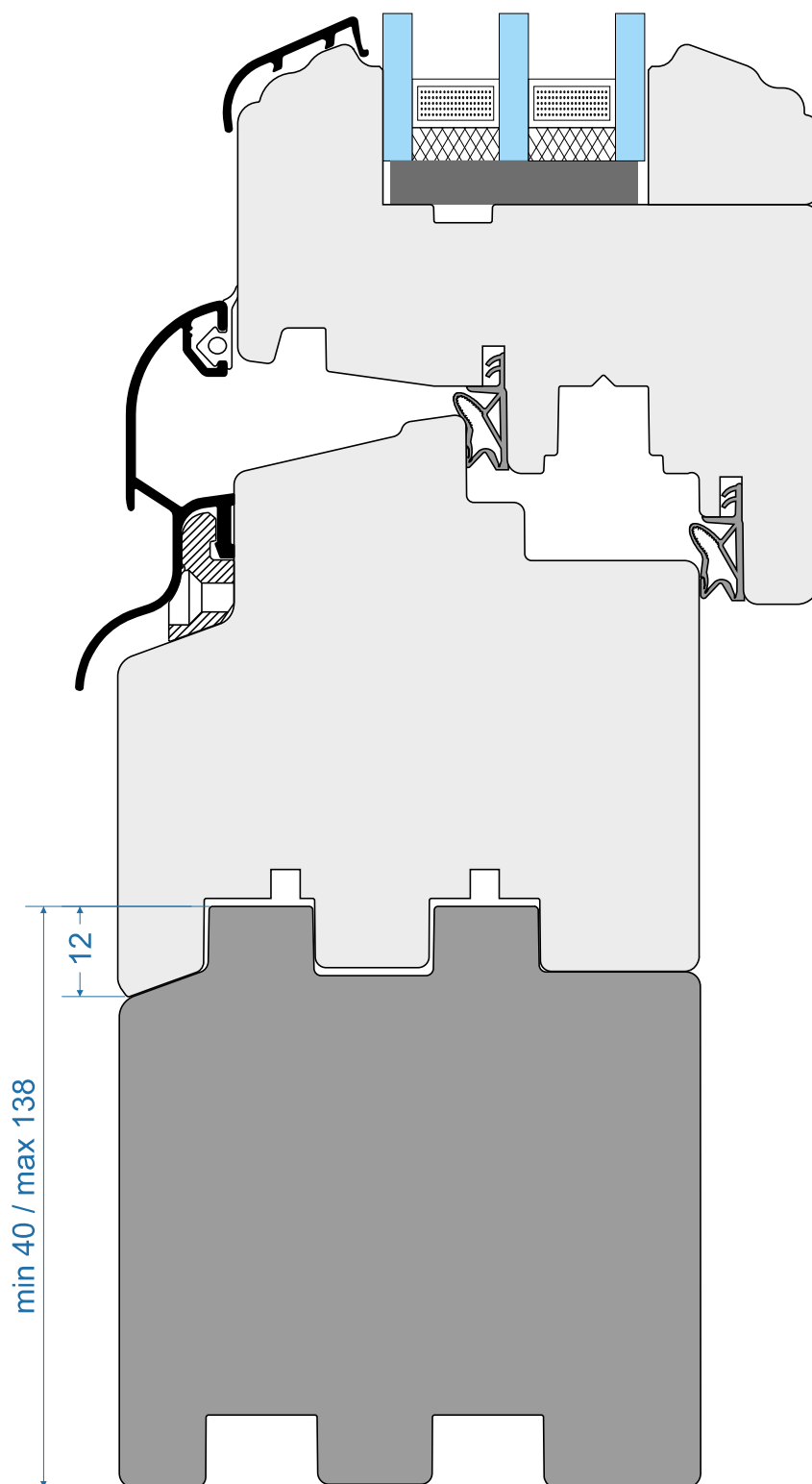

out

in



-  Dolne poszerzenie ramy
-  Lower frame extension
-  Élargissement inférieure du cadre
-  Estensione del telaio inferiore
-  Untere Rahmenverbreiterung

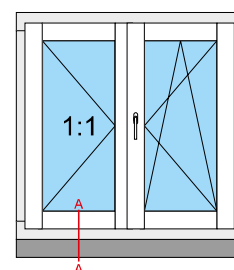

ENR-80-R-0041

Energio 80mm „S”

Energio 80mm „R”

Energio 80mm Classik „S”

Energio 80mm Classik „R”

Passiv 92mm „S”

Passiv 92mm „R”

Energio 80mm „S”

Energio 80mm „R”

Energio 80mm Classik „S”

Energio 80mm Classik „R”





Passiv 92mm „S”

Passiv 92mm „R”

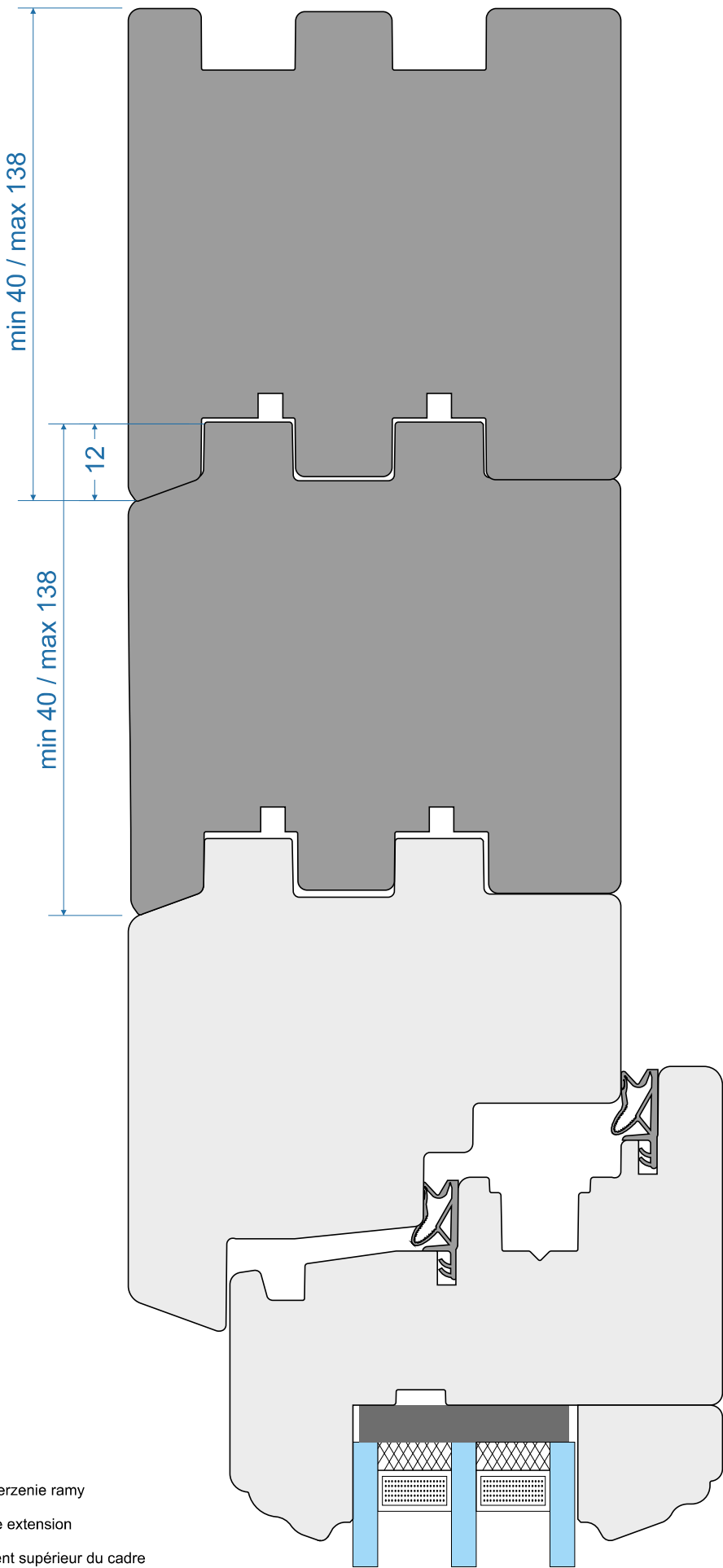
out

in



-  Górne poszerzenie ramy
-  Upper frame extension
-  Élargissement supérieur du cadre
-  Estensione del telaio superiore
-  Obere Rahmenverbreitung

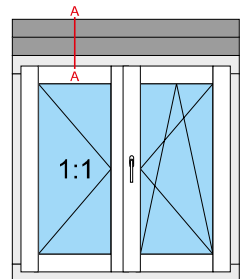





out

in

min 57 / max 138

12

12

-  Środkowe poszerzenie ramy
-  Middle frame extension
-  Montant d'assemblage
-  Montante di accoppiamento
-  Zentral Rahmenverbreiterung

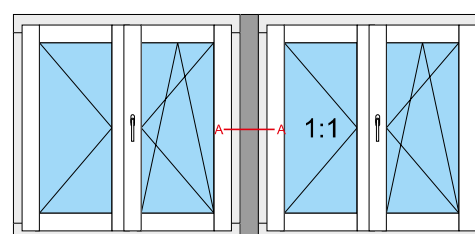

ENR-80-R-0043

Energio 80mm „S”

Energio 80mm „R”

Energio 80mm Classik „S”

Energio 80mm Classik „R”

Passiv 92mm „S”

Passiv 92mm „R”

Energio 80mm „S”

Energio 80mm „R”

Energio 80mm Classik „S”

Energio 80mm Classik „R”





Passiv 92mm „S”

Passiv 92mm „R”

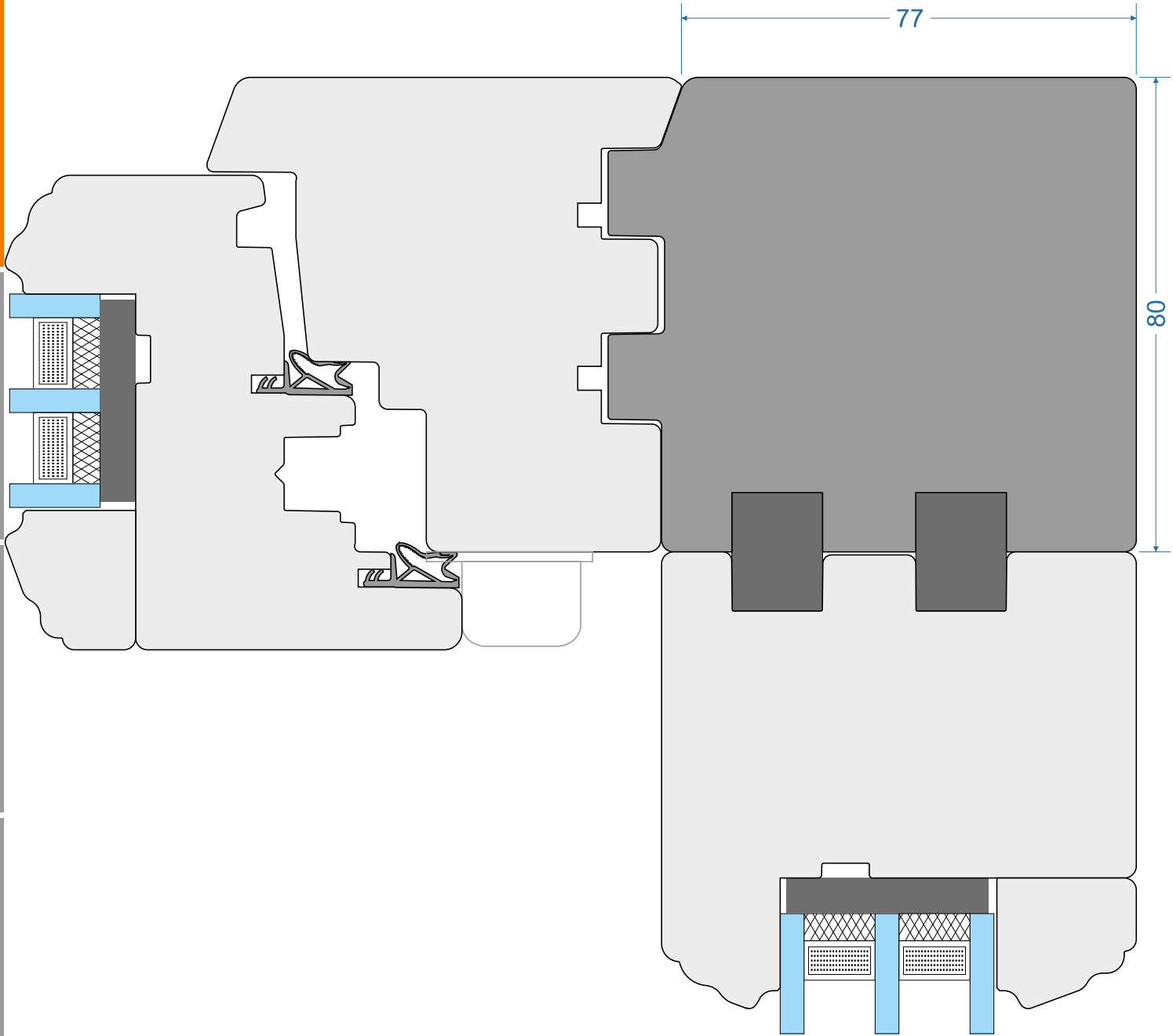
out

in



-  Łącznik 90 stopni
-  90 degree corner connecting post
-  Montant d'assemblage à 90 degrés
-  Montante di accoppiamento 90 gradi
-  90-Grad-Eckpfosten

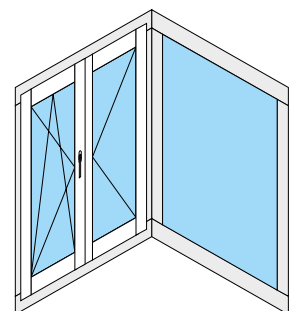

out

in

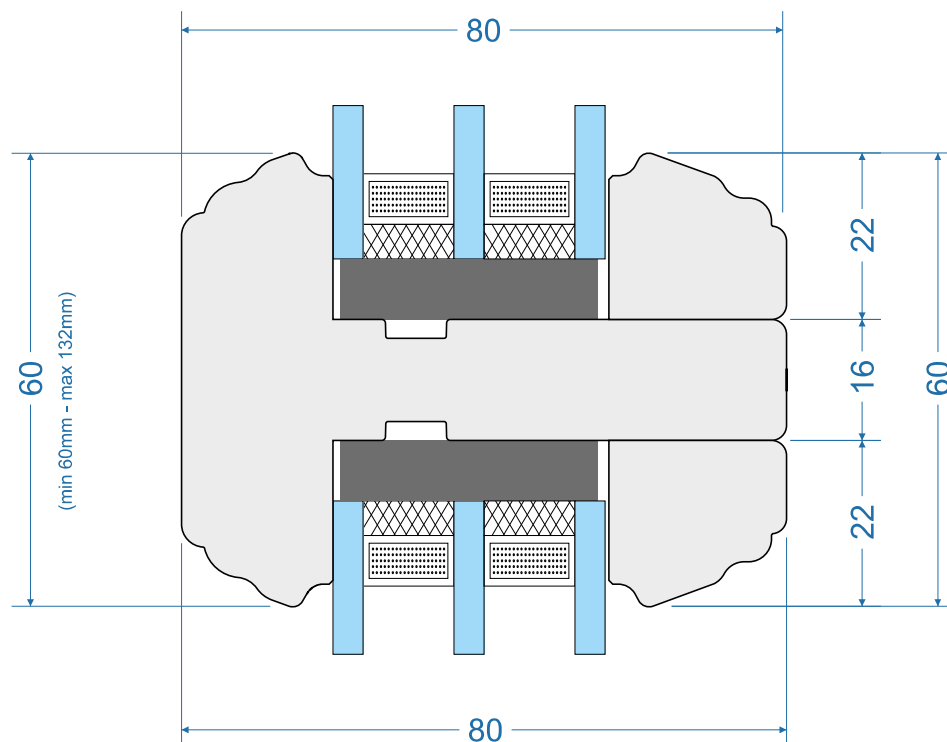

-  Szpros konstrukcyjny
-  Construction type muntin
-  De vrais crossillon
-  Traverso
-  Glasteilende Sprosse

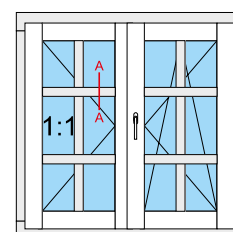

ENR-80-R-0045

Energio 80mm „S”

Energio 80mm „R”

Energio 80mm Classik „S”

Energio 80mm Classik „R”

Passiv 92mm „S”

Passiv 92mm „R”

Energio 80mm „S”

Energio 80mm „R”

Energio 80mm Classik „S”

Energio 80mm Classik „R”

Passiv 92mm „S”

Passiv 92mm „R”

out

in

W-01

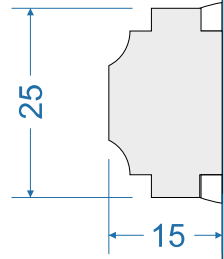

W-02

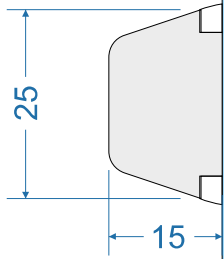

W-03

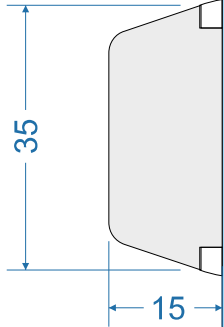



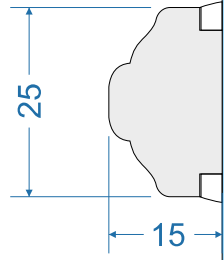

W-04

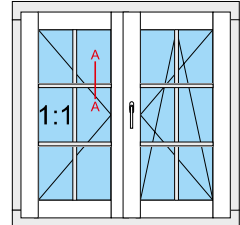
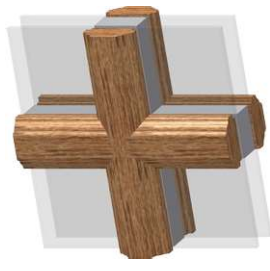
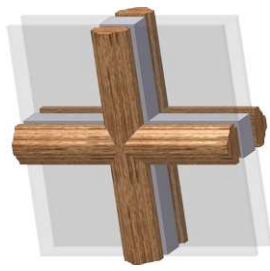
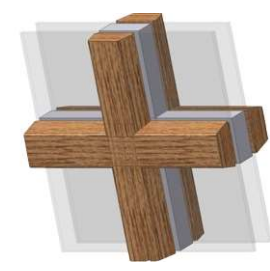
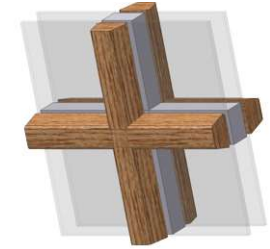
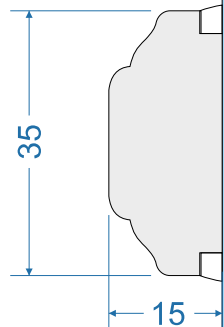

W-05



-  Szpros wideński (Duplex)
-  Vienna muntin (Duplex)
-  Petits bois Viennoise (Duplex)
-  Traverse incollate Viennese (Duplex)
-  Wiener Sprosse (Duplex)

out

in

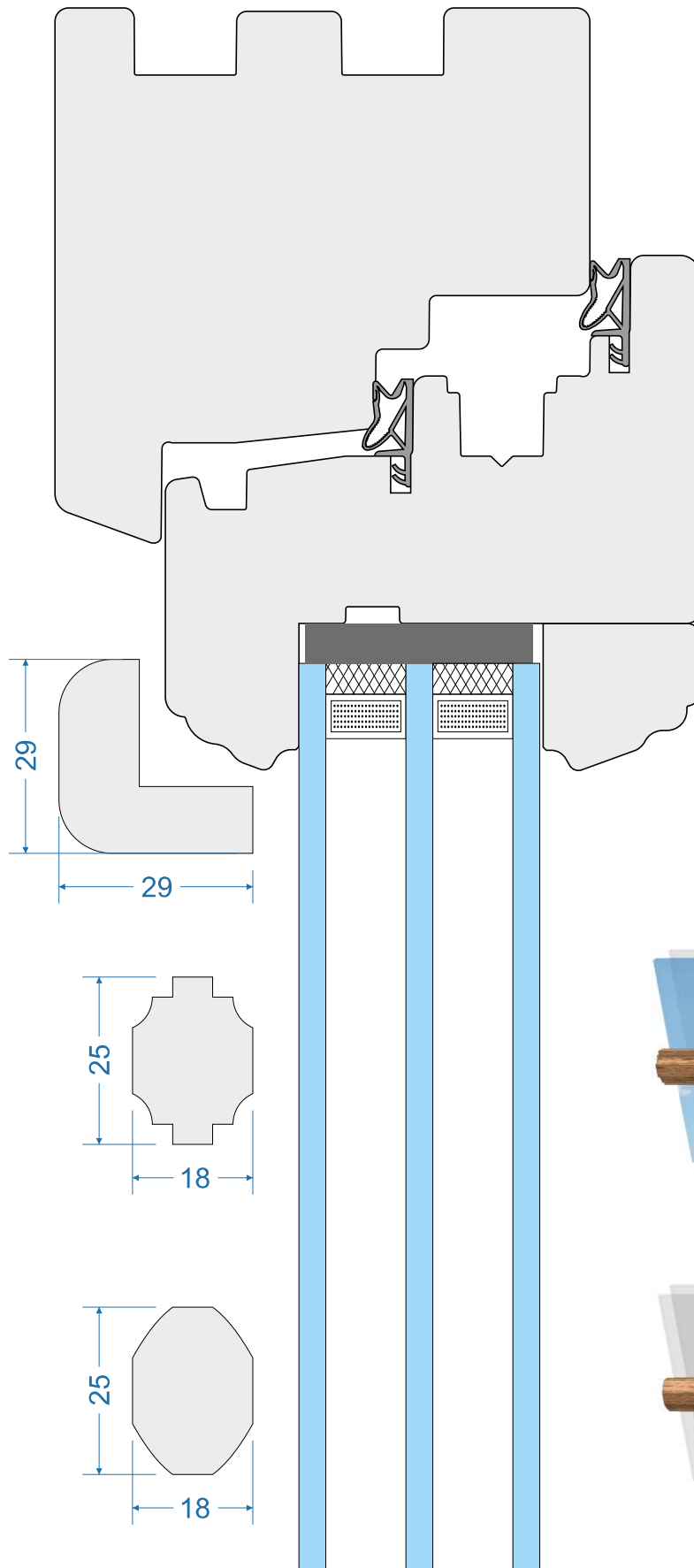

P-01

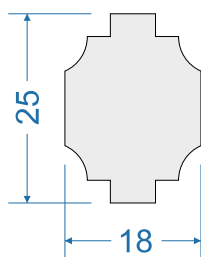

P-02

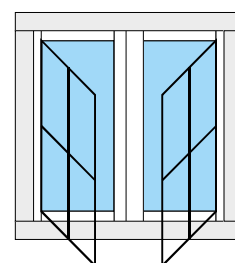
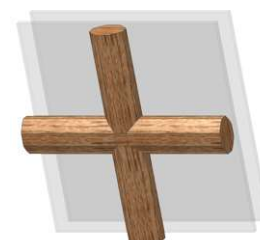
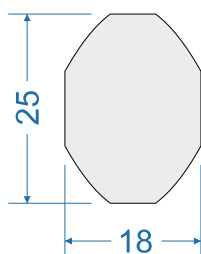

-  Szpros otwierany
-  Openable muntin
-  Croisillon ouvrable
-  Montatura apribile
-  Aufklappbare Sprossen